

Compact and Versatile



Datasheet

power contactors

4 POLE

SIEMENS



Introduction :

The 4 pole contactors type 3RT13 and 3RT15 are specially designed to meet specific applications. These contactors are highly reliable, user friendly and meets the expectation of world class Siemens products. They conform to the latest IEC60947-4-1 standard and carry CE marking.

Application:

Some of the common applications of 4 pole contactors are:-

- As incomer in a source changeover systems requiring neutral isolation.
- 2 pole, AC1 applications (using 2 poles in parallel, 1.8 times rating).
- As contactors for DG incomer.
- Isolating powers systems with unearthed or poorly earthed systems.
- Switching resistive loads.
- Changing the polarity of hoisting gear motors.

Features:

High on performance and reliability:

Superior design of current carrying parts, magnet and the contact systems ensures a high mechanical and electrical life of the contactors.

High on operator safety:

The 4 pole contactors have the patented Siemens SIGUT® termination technique. The finger touch proof terminals prevent accidental contact with live parts thereby ensuring operator safety.

User friendly and ease of maintenance

Ready to wire terminals, cable end stops and predetermined insertion depth reduces the wiring time considerably. Also identification and replacement of coils is relatively simple which reduces maintenance time.

Accessories:

a) Add on Auxiliary contact block:

3RT13/15: Facility to add on a maximum of 2 auxiliary contacts (1 NO or 1 NC) for contactors size S0 (Pls. Check with us in case 4 auxiliary contact blocks are required) and up to 4 Auxiliary contacts for contactors of size S00, S2 and S3.

b) Mechanical Interlocking kit:

Front mounting mechanical interlock kit is available for interlocking two 4-pole contactors of the same size.

c) Surge Suppressor:

The surge suppressors are available as an accessory for the entire range of 4 pole, AC1 duty contactors, to limit the voltage surges. Hence the contactors are suitable for use in conjunction with electronic circuits. The surge suppressors can be snap fitted onto the contactor.

Installation:

The 3RT13/15 contactors are suitable for screw mounting on to a base plate or snap fitting on to a standard 35mm Din rail (75mm for S3).



Selection Table

4Pole, AC1 Duty Contactors			
No of main Contacts		4 NO	2 NO + 2 NC
Size	Rating I _e (AC1) amp	MLFB * (Pls. fill in .. with coil voltage)	MLFB * (Pls. fill in .. with coil voltage)
S00	18A	3RT13 16 1A..0	3RT15 16 1A..0
	22A	3RT13 17 1A..0	3RT15 17 1A..0
S0	35A	3RT13 25 1A..0	–
	40A	3RT13 26 1A..0	3RT15 26 1A..0
S2	55A	–	3RT15 35 1A..0
	60A	3RT13 36 1A..0	–
S3	110A	3RT13 44 1A..0	–
	140A	3RT13 46 1A..0	–

(..) Coil voltage code for AC coils, 50Hz

3RT13/15 : F0 = 110V, P0 = 230V and V0 = 400V

* Contactors with DC coils are also available upon request.



Technical Data

Contactors	Size	S00		S0		S2		S3	
4 NO 2 NO + 2 NC	Type	3RT13 16 3RT15 16	3RT13 17 3RT15 17	3RT1325	3RT1326 3RT15 26	3RT1336	3RT1535	3RT1344	3RT1346

General Data

Rated Insulation Voltage	V	690
Permissible Ambient Temperature	in operation °C	-25..+60
	in storage °C	-55..+80
Mechanical Endurance	cycles	30 mill. 10 mill.
Electrical Endurance at Ie/AC1	cycles	0.5 mill.

Main Circuit

AC1 Duty (switching resistive loads)											
Rated operational current Ie	at 40° C	upto 690V	A	18	22	35	40	60	55	110	140
	at 60° C	upto 690V	A	16	20	30	35	55	50	100	120
Rating of 3 phase loads (p.f = 0.95)	at 230V		kW	7	8.5	12.5	15	23	20	42	53
	at 415V		kW	12	14.5	22	26	39	36	72	92
AC2 and AC3 Duty											
Rated operational current Ie	at 415V		A	9	12	17	25	26	40	-	-
Maximum rating of slipping or squirrel cage motors at 50/60Hz	at 415V		kW	4	5.5	7.5	11	11	18.5	-	-

Control Circuit

Coil Voltage Tolerance		AC/DC	at 50 Hz	AC/DC: 0.8-1.1 X Us			
Power consumption of the coils	Closing		VA	26.5	61	145	270
	AC operation, at 50Hz	p.f		0.79	0.82	0.79	0.68
		Closed p.f		VA	4.4	7.8	12.5
DC operation	closing=closed			0.27	0.24	0.36	0.27
			W	3.3	5.6	13.3	15
Operating times at 0.8..1.1xUs							
Closing time	AC operation		ms	8...35	6...30	4...35	20...50
			ms	25...100	30...90	50...110	110...200
Opening time	AC operation		ms	4...30	13...25	10...30	10...25
			ms	7...10	13...40	15...30	14...20
Operating frequency	No Load	AC	cycles/hr	10000	5000	5000	5000
		DC	cycles/hr	10000	1500	1500	1000
	at AC1	AC/DC	cycles/hr	1000	1000	1000	1000
							900

Short-Circuit Protection

Main Circuit (Fuse type 3NA)	Co-ordination								
	Type-1	A	35	63	63	160	160	250	250
	Type-2	A	20	25	35	63	80	125	160

Accessories

For Contactor	3RT13 16/17 3RT15 16/17	3RT1325/26 3RT1526	3RT1336 3RT1535	3RT1344/46
---------------	----------------------------	-----------------------	--------------------	------------

Aux. Contacts (front mounting)

1 NO	-	3RH19 21 1CA10
1 NC	-	3RH19 21 1CA01
1NO+1NC	3RH19 11 1FA11	-
2NO+2NC	3RH19 11 1FA22	- 3RH19 21 1FA22

Surge Suppressors

AC 48V-127V	3RT1916 1BC00	3RT19 26 1BC00
AC 127V-240V	3RT1916 1BD00	3RT19 26 1BD00
AC 240V-400V	3RT1916 1BE00	3RT19 26 1BE00

Mechanical Interlocks

Front mountable	3RA19 12 2H	3RA19 24 1A
-----------------	-------------	-------------



Dimensions (mm)

3RT15 1 contactors

Size S00, screw connection with surge suppressor and auxiliary switch block

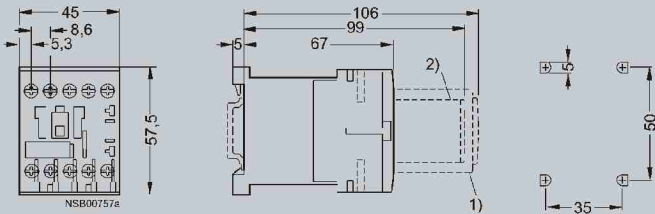

For size S00:

- 1) Auxiliary switch block
- 2) Surge suppressor

3RT13 2 and 3RT15 2 contactors

Size S0, with surge suppressor and auxiliary switch block

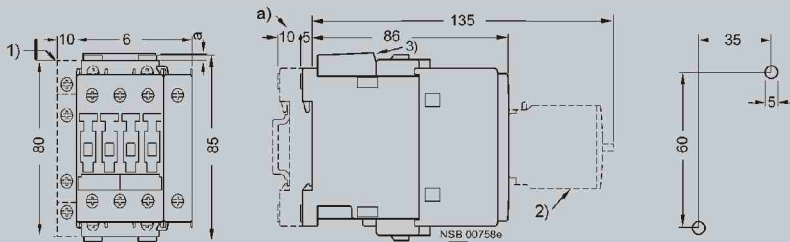

For size S0:

- a = DC 10 mm deeper than AC
- 1) Auxiliary switch block, laterally mountable (left)
 - 2) Auxiliary switch block, mountable on the front, 1, 2 and 4-pole
 - 3) Surge suppressor

3RT13 3 and 3RT15 3 contactors

Size S2, with surge suppressor and auxiliary switch block

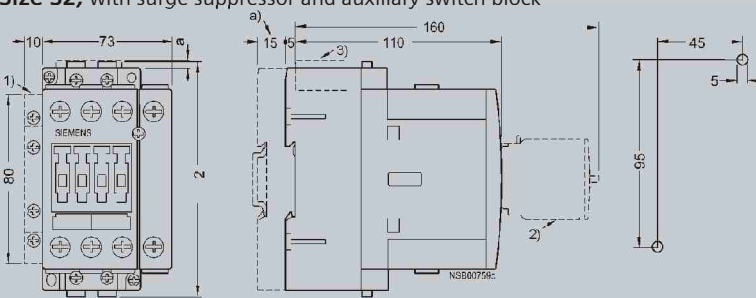

For sizes S2 and S3:

a = S2: DC 15 mm deeper than AC
S3: DC 13 mm deeper than AC

- 1) Auxiliary switch block, laterally mountable (left)
- 2) Auxiliary switch block, mountable on the front,
- 3) Surge suppressor
- 4) For mounting on 35 mm standard mounting rail (15 mm deep) acc. to EN 50 022 or 75 mm standard mounting rail acc. to EN 50 023

3RT13 4 contactors

Size S3, with surge suppressor and auxiliary switch block

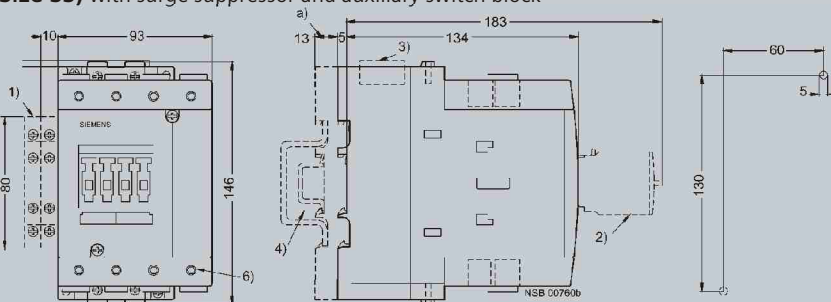

Siemens Ltd.

Automation & Drives Division
LV Controls & Distribution Products
Thane Belapur Road
Thane - 400 601
Fax: +91 22 27600076
E-mail: AD.CDPM@kwa2.siemens.co.in

Siemens Ltd.
SGR-01-101-069

'Product development is a continuous process. Consequently the data indicated in this leaflet is subject to change without prior notice. For latest issue contact our Sales Office.'

SICOP

Datasheet 2010



Low Voltage Control Components

Answers for industry.

SIEMENS



Index

Contents	Page No.
3TH30 – Contactor Relays	3
3TF – Power Contactors	7
3TF – Contactors for Hoisting Duty	25
3TK5 – AC1 Duty Contactors	29
3UA and 3UC – Bimetal Overload Relays	33
3VU13 and 3VU16 – Motor Protection Circuit Breakers	45
3TW and 3TE – Starters	55

Contactor Relays 3TH30

Reliability and safety are pre-requisites in the choice of the control contactor. Siemens 3TH30 contactor relays satisfy these criteria and thus offer the right choice to the customer.

Applications

3TH30 are used in control circuits for switching and signaling purpose. Also they are used for interfacing with the electronic circuits.

Standards

Contactor relay conforms to IS /IEC 60947-5-1.

They also carry CE mark.

Range

Air break contactor relays are suitable for 10A, (AC15/AC14 rating) at 240V AC and 10A, (DC13 rating) at 24V DC.

Benefits and features

Flexibility

- **Choice of auxiliary contacts**

3TH30 contactor relays comes with 4 contacts as a basic unit (4NO, 3NO+1NC, 2NO+2NC). However the contacts can be extended upto 8 contacts by adding maximum 4 auxiliary contact blocks to this basic unit. This offers flexibility in selection and configuration.

- **Choice of mounting**

3TH30 can be mounted on 35mm DIN rail and they are also suitable for screw mounting.

Long Life

Superior design of current carrying parts, contact system and the magnet system increases the reliability which also results into higher **electrical and mechanical endurance**.

High reliability

- **Double Break Parallel Bridge contact mechanism**

This mechanism is available with 3TH30. Such contact mechanism ensures reliable contact at low voltage and low currents (5mA at 17V DC). It also offers unmatched reliability as well as capability to integrate directly into PLC or instrumentation circuits.



User friendliness and safety

- **Positively driven contacts**

3TH30 auxiliary contactors satisfy the conditions **for positively driven operation** between NO and NC contacts. NO and NC contact do not close at the same time. This is extremely important when they are used in safety circuits of critical applications. This ensures operator safety even during abnormal condition.

- **SIGUT Termination**

- **Figure touch proof terminals**

It protects against accidental contact with live parts which ensures operator safety.

- **Funnel shaped cable entries**

Reduce wiring time by facilitating quick location of the connecting wire.

- **Cable end-stop**

It decides the insertion depth of the connecting wires. Since the insertion depth is predetermined, insulation of the cable can be cut accordingly and the possibility of insulation getting inadvertently caught under the terminal is avoided.

- **Captive Screws**

This feature prevents the screws from falling down thereby facilitates the wiring. Hence, the auxiliary contactors are delivered with untightened terminals. This eliminates the operation of untightening terminals before wiring.

- **Lug less termination**

This feature helps in reducing the termination time.

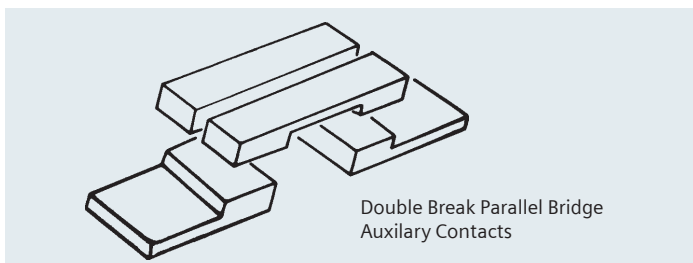

Selection and ordering data

Contacts in basic unit	MLFB - With AC coil	MLFB - With DC coil	Std. pkg. (nos.)
4NO	3TH30 40-0A..	3TH30 40-0B..	1
3NO+1NC	3TH30 31-0A..	3TH30 31-0B..	
2NO+2NC	3TH30 22-0A..	3TH30 22-0B..	

.. Please add coil voltage code

AC Coil voltages

Coil voltage	24	42	110	230	415
Code	B0	D0	F0	P0	R0

DC Coil voltages

Coil voltage	24	42	48	110	220	250
Code	B4	D4	W4	F4	M4	N4

(Other coil voltages are also available.)

Technical data

Type	3TH30			3TX40..			
Standards	IS/IEC 60947-5-1						
Rated Operational Voltage	690V						
Rated Impulse withstand voltage	8kV						
Permissible ambient temp.	Storage	-50 to +80°C					
	Service	-25 to +55°C					
Mechanical endurance cycles	30 mill			10 mill			
Rated operating current Ie/AC12	16A			10A			
Rated operating current Ie/AC15/AC14 at operating voltage	230V	10A			5.6A		
	415V	4A			3.6A		
	690V	2A			1.8A		
Rated operating current Ie/DC13 at operating voltage	Current paths in series			Current paths in series			
		1	2	3	1	2	3
	24V	10 A	10A	10A	10 A	10A	10A
	110V	0.9 A	2.5A	10A	0.8 A	3.8A	10A
	220V	0.45A	0.75A	2A	0.2 A	0.85A	2A
440V	0.2 A	0.5A	0.9A	0.11A	0.2A	0.5A	
Coil Voltage tolerance	0.8 to 1.1 x Ue						
Rated coil input AC operated, 50Hz	Closing VA/p.f.	68 / 0.82					
		When closed VA/P.f.	10 / 0.29				
DC operated Closing=when closed	W		6.2				
Frequency of operation at AC15/DC13 duty	cycles/hr	3600					
Short circuit protection HRC fuse-links Miniature circuit breakers, (C-char.)	16A			16A			
	16A			10A			
	Degree of protection						
IP 20							

For 3TH30

Operating time at 1.0*Us		AC	DC
Closing	Closing Delay NO	10-25 ms	30-70ms
	Opening Delay NC	7-20ms	28-56 ms
Opening	Opening Delay NO	5-18ms	10-20 ms
	Closing Delay NC	7-20ms	15-25 ms

Accessories and ordering data

1. Surge suppressor

It is used to reduce the effect of switching overvoltages created during the opening of inductive circuits. Typically they are mounted outside the body of the contactor relay, and are connected in parallel with the coil terminals. Various techniques for the suppression of switching overvoltages can be employed. For example: RC element, Varistor etc

2. Add on blocks

Auxiliary Contact Block	Type Reference	Std. pkg. (nos.)
1NO	3TX40 10 2A	10
1NC	3TX40 01 2A	
1NO extended	3TX40 10 4A	
1NC extended	3TX40 01 4A	

Extended contacts (NO/NC) is *early make NO* and *late break NC* combination.

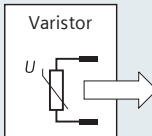
Varistor	Surge Suppressor (Varistor)			
	Coil voltage		MLFB	Std. pkg. (nos.)
	AC	DC		
	24 - 48 V	24 - 70 V	3TX7 402-3GY1	10
	48 - 127 V	70 - 150 V	3TX7 402-3HY1	
	127 - 240 V	150 - 250 V	3TX7 402-3JY1	
	240 - 400 V	–	3TX7 402-3KY1	
	400 - 460 V	–	3TX7 402-3LY1	

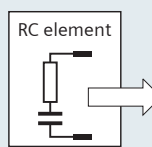
RC element	Surge Suppressor (RC Element)			
	Coil voltage		MLFB	Std. pkg. (nos.)
	AC	DC		
	24 - 48 V	24 - 70 V	3TX7 402-3RY2	10
	48 - 127 V	70 - 150 V	3TX7 402-3SY2	
	127 - 240 V	150 - 250 V	3TX7 402-3TY2	
	240 - 400 V	–	3TX7 402-3UY2	
	400 - 460 V	–	3TX7 402-3VY2	

Dimensional drawings

3TH30 - 0A

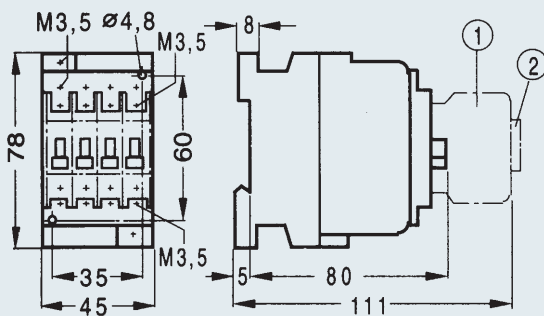

3TH30 - 0B

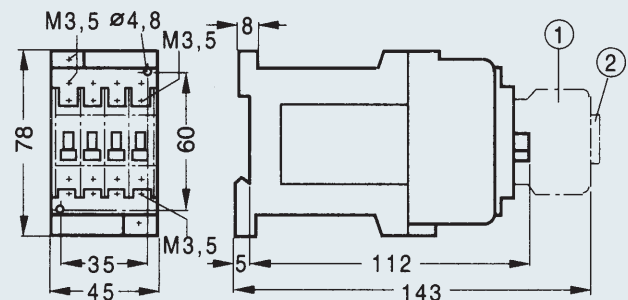

- ① Auxiliary Contact Block
- ② Identification tag

Useful technical information

Variety of connections for DC applications

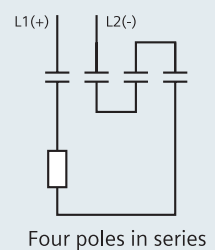
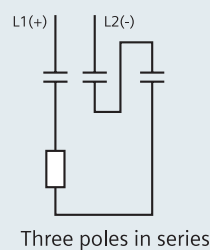
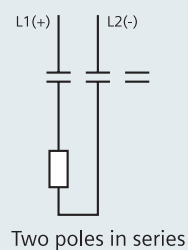
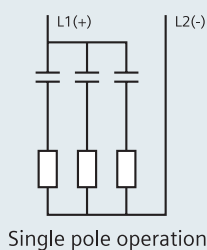



Power Contactors 3TF

For more than 110 years, Siemens has been developing and manufacturing industrial control products. We offer a wide product range which fulfills the demands of our customers regarding performance and reliability. Our aim is to make industrial operation easier ensuring flexible mounting, modular construction and high functionality. With 3TF contactors Siemens has been offering a tried tested trusted solution to control, switch and protect your motors upto 250kW.

Applications

3TF power contactors are suitable for switching and controlling squirrel cage and slip-ring motors as well as other AC loads, such as solenoids, capacitors, lighting loads, heating loads and transformer loads.

Standards

Contactors conform to IS/IEC 60947-4-1. They also carry the CE mark.

Coordinated feeder

Contactors and bi-relays have been tested for type-2 coordination at $I_q = 50kA$, 415V AC, 50Hz as per IS/IEC 60947-4-1, for both fuse protected as well as fuseless motor feeders.

Range

Air break contactors are available from 9 A to 475A in 3 pole version.

Also available in 2 pole AC version from 45A to 400A.

Benefits and features

Flexibility

- Choice of Auxiliary contacts

Contactor	Aux. contacts on basic unit	Permissible add-on contact blocks
9A / 12A	1 NO	Upto 4NO or 4NC
9A / 12A	1 NC	Upto 4NO or 2NC
16A/22A	-	Upto 4NO or 4NC
32A/38A	-	Upto 4NO or 4NC
45A to 475A	2NO+2NC	2 x (1NO+1NC)

The customer can order desired number of contacts thereby reducing the cost.

- Choice of mounting

Contactor can be mounted on 35mm DIN and they are also suitable for screw mounting (9-38A – DIN / Screw mounting and 45-475A – Screw mounting).



- Choice of coil voltages

AC 50Hz coil code: 3TF30 to 3TF56

Coil voltage (V)	24	42	110	230	415
Code	B0	D0	F0	P0	R0

Wide band AC 50 Hz coil code: 3TF30 to 3TF35

Coil voltage (V)	70-140	150-280	260-460
Code	W110	W220	W415

AC 50/60 Hz coil code: 3TF57

Coil voltage (V)	110-132	220-240	380-460
Code	F7	M7	Q7

DC coil code: 3TF30 to 3TF57

Coil voltage (V)	24	42	48	110	220	250 ⁺
Code	B4	D4	W4	F4	M4	N4

⁺ For 3TF3 only

(Other coil voltages are also available.)

High performance

- **No duration upto 55°C**
Contactors are suitable for operation in service temperature upto 55°C without derating. This avoids selection of higher rated contactor, thereby reducing cost.
- **Long Life**
Superior design of current carrying parts, contact system and the magnet system increases the reliability results into **higher electrical and mechanical endurance**.
- **High short-time rating**
Contactors have a high short-time rating, which makes them suitable for applications having high starting currents and long run-up times.

High reliability

- High insulation voltage and impulse withstand voltage capacity ensures reliable performance during occasional abnormal increase in supply voltage.
- **Double break parallel bridge contact mechanism**
This mechanism is available for auxiliary contacts. Such contact mechanism ensures reliable contact at low voltage and low currents (5mA at 17VDC). It also offers unmatched reliability. (Chances of 2 mal-operations in 100 mill. operations as against 4460 for single bridge contacts)

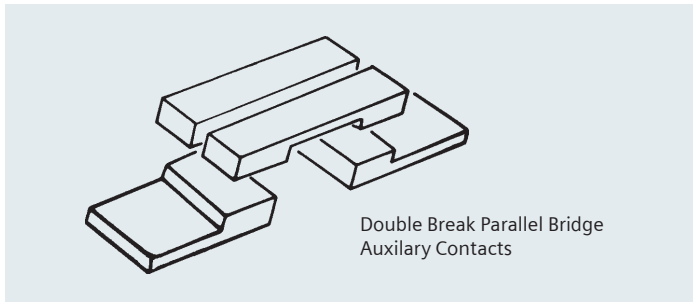

User friendliness and safety

- **Arc Chamber Interlock (45A and above)**
It prevents the contactor from switching ON, if the arc chamber is not fitted properly. Thus avoids accidents to plant and personnel.



- **Positively driven contacts**
3TF contactors satisfy the conditions **for positively driven operation** between the main power contacts and the NC contacts. NC contacts positively open before the main contact closes. This is extremely important when power contactors are used in safety circuits of critical applications.

SIGUT Termination

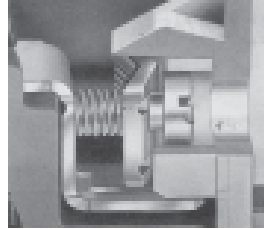

- **Figure touch proof terminals***
It protects against accidental contact with live parts which ensures operator safety.
- **Funnel shaped cable entries**
Reduce wiring time by facilitating quick location of the connecting wire.
- **Cable end-stop**
It decides the insertion depth of the connecting wires. Since the insertion depth is predetermined, insulation of the cable can be cut accordingly and the possibility of insulation getting inadvertently caught under the terminal, is avoided.
- **Captive Screws**
This feature prevents the screws from falling down thereby facilitates the wiring. Hence, the contactors are delivered with untightened terminals. This eliminates the operation of untightening terminals before wiring.
- **Lug less termination**
This feature helps in reducing the termination time.

* Finger touch proof terminals are available upto 85 A

Selection and ordering data

Contactor size	Rated current (A) Ie AC3 at 415V, 50Hz, 3ph	Motor kW at 415V 50Hz, 3ph	Auxiliary contacts	AC 50 Hz coil Type Pl. fill in coil voltage code	DC coil Type Pl. fill in coil voltage code	Std. pkg. (nos.)
0	9	4	1NO ^{\$} 1NC ^{\$}	3TF30 10-0A.. 3TF30 01-0A..	3TF30 10-0B.. 3TF30 01-0B..	1
	12	5.5	1NO ^{\$} 1NC ^{\$}	3TF31 10-0A.. 3TF31 01-0A..	3TF31 10-0B.. 3TF31 01-0B..	
1	16	7.5	— ^{\$}	3TF32 00-0A..	3TF32 00-0B..	
	22	11	— ^{\$}	3TF33 00-0A..	3TF33 00-0B..	
2	32	15	— ^{\$}	3TF34 00-0A..	3TF34 00-0B..	
	38	18.5	— ^{\$}	3TF35 00-0A..	3TF35 00-0B..	
3	45	22	2NO + 2NC ^{\$}	3TF46 02-0A..ZA01 [®]	3TF46 02-0D..ZA01 [®]	
	63	30	2NO + 2NC ^{\$}	3TF47 02-0A..ZA01 [®]	3TF47 02-0D..ZA01 [®]	
	70	37	2NO + 2NC ^{\$}	3TF47 72-0A..	3TF47 72-0D..	
4	75	42	2NO + 2NC ^{\$}	3TF48 22-0A..ZA01 [®]	3TF48 22-0D..ZA01 [®]	
	85	45	2NO + 2NC ^{\$}	3TF49 22-0A..ZA01 [®]	3TF49 22-0D..ZA01 [®]	
6	110	55	2NO + 2NC ^{\$}	3TF50 02-0A..	3TF50 02-0D..	
	140	75	2NO + 2NC ^{\$}	3TF51 02-0A..	3TF51 02-0D..	
8	170	90	2NO + 2NC ^{\$}	3TF52 02-0A..	3TF52 02-0D..	
	205	110	2NO + 2NC ^{\$}	3TF53 02-0A..	3TF53 02-0D..	
10	250	132	2NO + 2NC ^{\$}	3TF54 02-0A..	3TF54 02-0D.. ¹⁾	
	300	160	2NO + 2NC ^{\$}	3TF55 02-0A..	3TF55 02-0D.. ¹⁾	
12	400	200	2NO + 2NC ^{\$}	3TF56 02-0A..	3TF56 02-0D.. ¹⁾	
	475	250	2NO + 2NC ^{\$}	3TF57 02-0C..	3TF57 02-0D.. ¹⁾	

¹⁾ Please connect DC coil circuit as recommended on page 16

^{\$} For more auxiliary contacts please refer table below - "auxiliary contact blocks"

[®] For box type (SIGUT) terminal, order 2 nos. 3TX7 460-0E

Coil voltage code AC 50Hz: 3TF30 to 3TF56

Coil voltage	24	42	110	230	415
Code	B0	D0	F0	P0	R0

Coil voltage code AC 50/60 Hz: 3TF57

Coil voltage (V)	110-132	220-240	380-460
Code	F7	M7	Q7

Coil voltage code DC: 3TF30 to 3TF57

Coil voltage (V)	24	42	48	110	220	250 ⁺
Code	B4	D4	W4	F4	M4	N4

⁺ For 3TF3 only

²⁾ Coil voltage code AC 50Hz: 3TF (2 Pole AC Contactor)

Coil voltage	110	230	415
Code	F0	P0	R0

(Other coil voltages are also available)

Auxiliary contact blocks

For Contactor	Description	Type	Std. pkg. (nos.)
3TF30 to 35	1NO 1NC 1NO ext 1NC ext	3TX4 010-2A 3TX4 001-2A 3TX4 010-4A 3TX4 001-4A	10
3TF46 to 57	Second 1NO+1NC Left Second 1NO+1NC Right	3TY7 561-1K 3TY7 561-1L	1

2 Pole AC contactors - 3TF

For single phase and 2 phase applications with AC coils

Contactor Size	Rated current Ie (A) AC3, 415V	Type ²⁾	Std. pkg. (nos.)
3	45	3TF46 02-0A..ZB01	1
3	63	3TF47 02-0A..ZB01	
3	70	3TF47 72-0A..ZB01	
6	110	3TF50 02-0A..ZB01	
6	140	3TF51 02-0A..ZB01	
8	170	3TF52 02-0A..ZB01	
8	205	3TF53 02-0A..ZB01	
10	250	3TF54 02-0A..ZB01	
10	300	3TF55 02-0A..ZB01	
12	400	3TF56 02-0A..ZB01	

Technical data

Contactor	Size	0			1		2				
		Type	3TF30	3TF31	3TF32	3TF33	3TF34	3TF35			
Permissible ambient temperature	Storage Service	°C	-55 to +80								
		°C	-25 to +55								
Maximum operating voltage		V	690								
Rated insulation voltage U_i (At Pollution Degree 3) ¹⁾		V	690								
Rated impulse strength U_{imp}		kV	8								
Mechanical endurance (make/break operations)	AC	Cycles	15 x 10 ⁶				10 x 10 ⁶				
	DC	Cycles	15 x 10 ⁶				10 x 10 ⁶				
Rating of contactors for AC loads											
AC-1 duty, switching resistive load											
Rated operational current I_e	at 40°C upto 690V	A	21		32		65				
	at 55°C upto 690V	A	20		30		55				
Ratings of three-phase loads	p.f.=1 at 55°C										
	at 415V	kW	13		19.7		36				
	500V	kW	17		26		47.5				
	690V	kW	22		34.		62.7				
AC-2 and AC-3 duty											
Rated operational current $I_e^{2)}$	upto 415V	A	9	12	16	22	32	38			
	500V	A	9	12	16	17	32	38			
	690V	A	6.6	8.8	12.2	12.2	27	27.			
Nominal rating of slipping or squirrel-cage motors at 50/60 Hz.	at 415V	kW	4	5.5	7.5	11	15	18.5			
	500V	kW	5.5	7.5	10	11	21	25			
	690V	kW	5.5	7.5	11	11	23	23.			
AC-4 duty (contact endurance approx. 2x10⁵ make-break operations at $I_a=6I_e$)											
Rated operational current I_e	upto 690V	A	3.3	4.3	7.7	8.5	15.6	18.5			
Rating of squirrel-cage motors at 50/60Hz.	at 415V	kW	1.54	2.1	3.5	4	8.2	9.8			
	500V	kW	1.7	2.5	4.6	5.2	9.8	11.8			
Max. permitted rated operational current $I_e/AC-4 = I_e/AC-3$ upto 500V. Ref. life curve for the life.	690V	kW	2.54	3.45	6	6.6	13	15.5			
Used as stator contactor (upto 690V) (AC-2 duty)											
Stator currents I_{es}	20%	A	20	20	25(46*)		85				
On-load factor (ED) ³⁾ with intermittent duty	40%	A	20	20	25(37*)		67				
	60%	A	20	20	25(33*)		60				
* Applicable up to 500V	80%	A	20	20	25(30*)		55				
Used as rotor contactor (upto 690V) (AC-2 duty)											
Rotor current I_{er}	20%	A	31		73		125				
On-load factor (ED) ³⁾ with intermittent duty	40%	A	31		58		106				
	60%	A	31		52		95				
	80%	A	31		47		87				
Locked rotor voltage U_{er}	Starting	V	1320		1320		1320				
	Plugging / Control	V	660		660		660				
AC-6b duty, switching low-inductance individual three-phase capacitors at 50/60Hz⁴⁾ (we also offer special capacitor duty contactors)											
	415V	kVAR	4		7.5		16.7				
	500V	kVAR	4		7.5		16.7				
	690V	kVAR	4		7.5		16.7				
Thermal loading	10 s current	A	90	96	130	176	400	400			
Power loss per current path at $I_e/AC-3$		W	0.6	1.1	1	1.6	2	2.5			
Rating of contactors for DC loads											
DC-1 duty, switching resistive load (L/R < 1mS)											
Rated operational current I_e (at 55°C)											
Number of current paths in series connection			1	2	3	1	2	3	1	2	3
	at 24V	A	20	20	20	30	30	30	55	55	55
	110V	A	2.1	12	20	4.5	30	30	6	55	55
	220V	A	0.8	1.6	20	1	5	30	1	6	45
	440V	A	0.6	0.8	1.3	0.4	1	2.9	0.4	1.1	2.9
DC-3 and DC-5 duty, shunt & series motors (L/R < 15mS)											
Rated operational current I_e (at 55°C)											
Number of current paths in series connection			1	2	3	1	2	3	1	2	3
	at 24V	A	20	20	20	20	30	30	20	55	55
	110V	A	0.15	0.35	20	0.75	7	30	0.75	7	55
	220V	A	-	-	1.75	0.2	1	3.5	0.2	1	3.5
	440V	A	-	-	0.2	0.09	0.27	0.6	0.1	0.27	0.6

1) As per I/IEC 60947-1

2) Ratings at 1000V AC - upon enquiry.

3) On-load factor (ED) in % = $\frac{\text{ontime} \times 100}{\text{cycle time}}$

Max. switching freq. z = 50 per hour. Ratings at higher frequency upon enquiry.

3			4			6			8			10		12	
3TF46	3TF47	3TF47 7	3TF48	3TF49	3TF50	3TF51	3TF52	3TF53	3TF54	3TF55	3TF56	3TF57			
			-55 to +80 -25 to +55												
1000			1000												
1000			1000												
8			8												
10 x 10 ⁶ 3 x 10 ⁶			10 x 10 ⁶ 3 x 10 ⁶												
90 80	100 90	100 90	120 100	120 100	170 160		230 210	240 220	325 300	325 300	425 400	600 550			
52 67 91	52 67 91	52 67 91	66 86 114	66 86 114	105 138 183		132 173 228	138 181 240	195 260 340	195 260 340	262 345 457	381 476 657			
45 45 45	63 63 63	70 70 70	75 75 75	85 85 75	110 110 110	140 140 110	170 170 170	205 205 170	250 250 250	300 300 250	400 400 400	475 475 400			
22 30 40	30 41.4 57.2	37 46 60.1	42 50.7 70	45 59 70	55 76.3 105	75 98 105	90 118 163	110 145 163	132 178 245	160 210 245	200 284 392	250 329 392			
24 13.1 15.8	28 15.3 18.4	31 16.9 20.4	34 18.6 22.4	42 23 27	54 29.5 35.5	68 38 46	75 42 50	96 54 65	110 63 76	125 72 86	150 88 107	150 88 107			
21.8	25.4	28.2	30.9	38	49	63	69	90	105	119	147	147			
123 98 87 80	138 110 98 90	138 110 98 90	154 122 109 100		246 195 174 160		323 256 229 210	339 268 240 220	462 367 327 300		617 490 436 400	800 670 600 550			
150 150 138 126 1500 750	219 174 155 142 1500 750	219 174 155 142 1500 750	243 193 172 158 2000 1000		389 309 275 253 2000 1000		510 405 361 332 2000 1000	535 425 378 348 2000 1000	729 579 516 474 2000 1000		972 772 688 632 2000 1000	1336 1061 946 869 2000 1000			
30 35 30			50 62.5 50		60 80 60		100 130 100		150 190 150		200 265 200				
360 3.5	500 6	500 6	800 7.5	800 10	880 10	1140 14	1360 14	1640 20	2500 16	2500 23	3400 40	4200 40			
1 80 6 1.2 0.48	2 80 80 7 1.2	3 80 80 80 3	1 100 12 2.5 0.8	2 100 100 13 2.4	3 100 100 100 6	1 160 18 3.4 0.8	2 160 160 20 3.2	3 160 160 160 11.5	1 200 18 3.4 0.8	2 200 200 200 3.2	3 200 200 200 11.5	1 300 33 3.8 0.9	2 300 300 300 4	3 300 300 300 11	
1 5 0.75 0.2 0.1	2 80 12.5 1.1 0.27	3 80 80 3.5 0.6	1 6 1.25 0.35 0.15	2 100 100 1.75 0.42	3 100 100 4 0.8	1 160 2.5 0.6 0.17	2 160 160 2.5 2.5 0.65	3 160 160 160 1.4	1 200 2.5 0.6 0.17	2 200 200 200 2.5 0.65	3 200 200 200 300 1.4	1 300 3 0.6 0.18	2 300 300 300 2.5 0.65	3 300 300 300 400 0.65	

4) Ratings for capacitor - banks in parallel - upon enquiry. Minimum inductance of 6µH required between parallel connected capacitors.

Power Contactors Technical Data

Contactor	Size	0		1		2		3				
		Type	3TF30	3TF31	3TF32	3TF33	3TF34	3TF35	3TF46	3TF47	3TF47 7	
Switching frequency z (Contactors without overload relay)		Operation										
No load	AC	Cycles/hr	10,000	10,000	5000	5000	5000	5000	5000	5000	5000	
		Cycles/hr	1,500	1,500	1,500	1,500	1,500	1,500	1,000	1,000	1,000	
	DC	at AC-1	Cycles/hr	2,000	2,000	1,500	1,500	1,200	1,200	1,000	1,000	1,000
		at AC-2	Cycles/hr	1,000	1,000	750	750	750	600	600	400	400
		at AC-3	Cycles/hr	1,000	1,000	750	750	750	600	1200 ⁵⁾	1000	1000
at AC-4	Cycles/hr	250	250	250	250	250	200	400	300	300		
Coil ratings (cold coil 1.0 x Us)		Supply frequency	Hz		50		50		50			
AC operation 50Hz	Closing	VA	68		68		101		183			
		p.f.	0.79		0.82		0.83		0.6			
	Closed	VA	10		10		12.1		17			
DC operation	Closing	W	6.2		6.2		11.7		400			
	Closed	W	6.2		6.2		11.7		2.1			
Coil voltage tolerance		Operation										
		AC/DC	0.8 to 1.1 x Us		0.8 to 1.1 x Us							
		at 24V DC	0.8 to 1.2 x Us									
Operating times at 1 x Us⁸⁾												
AC operation	Closing	ms	10-25		10 - 25		13 - 32		17 - 30			
	Opening	ms	4-18		5 - 20		5 - 10		5 - 25			
DC operation	Closing	ms	30-70		40 - 80		58 -107		22 - 40			
	Opening	ms	12-20		10 - 20		13 - 17		105 - 115			
Auxiliary contacts												
Rated thermal current I_{th} =												
rated operational current I_e / AC-12		A	10				10					
Rated operational current I_e / AC-15/AC-14												
at rated operational voltage U_e	upto 125V	A	10				10					
	220V	A	10				6					
	415V	A	5.5				3.6					
	500V	A	4				2.5					
Rated operational current I_e / DC12												
at rated operational voltage U_e	upto 48V	A	10				10					
	110V	A	2.1				3.2					
	220V	A	0.8				0.9					
	440V	A	0.6				0.33					
Rated operational current I_e / DC13												
at rated operational voltage U_e	upto 24V	A	10				10					
	48V	A	5				5					
	110V	A	0.9				1.14					
	220V	A	0.45				0.48					
	440V	A	0.25				0.13					
Conductor cross-sections												
Main conductor												
Solid	mm ²	2 x (0.5 to 1, 1 to 2.5), 1x4		2 x (2.5 to 6)		1 to 16		2 x (6 to 16)				
Finely stranded with end sleeve	mm ²	2 x (0.75 to 2.5)		2 x (1.5 to 4)		1 x (5 to 16, 2.5 to 10)		1 x (10 to 35), 2 x (10 to 25)				
Pin end connector	mm ²	1 x (1 to 2.5)		1 x (1 to 6)		2 x (1 to 6)		-				
Solid or stranded	AWG	2 x (18 to 12)		2 x (14 to 10)		2 x (14 to 6)		2 x (10 to 1/10)				
Tightening torque	Nm	0.8 to 1.4		1 to 1.5		2.5 to 3.0		4 to 6				
Finely stranded with cable lug	mm ²							10 to 35				
Terminal bar (max. width)	mm							12				
Solid or stranded	AWG							7 to 1/0				
Tightening torque	Nm							4 to 6				
Auxiliary conductor												
Solid	mm ²	2 x (0.5 to 1, 1 to 2.5), 1 x 4				2 x (0.5 to 1, 1 to 2.5), 1						
Finely stranded with end sleeve	mm ²	2 x (0.75 to 2.5)				2 x (0.75 to 2.5)						
Pin end connector	mm ²	1 x (1 to 2.5)				1 x (1 to 2.5)						
Solid or stranded	AWG	2 x (18 to 12)				2 x (18 to 12)						
Tightening torque	Nm	0.8 to 1.4				0.8 to 1.4						
Short-circuit protection												
Main circuit (Fuse type 3NA3)		Co-ordination										
Type - 1	A	35	35	63	63	80	80	160	160	160		
	A	25	25	32	32	80	80	125	125	160		
Type - 2	A	35	35	63	63	80	80	160	160	160		
	A	25	25	32	32	80	80	125	125	160		
Auxiliary circuits		A	16									
		A	6, if overload relay auxiliary contacts are in the contactor coil circuit									

5) With AC coil. With DC coil: 1000 oprs/hr.

6) Including switching contactor.

7) Rated value of the control voltage.

4		6		8		10		12	
3TF48	3TF49	3TF50	3TF51	3TF52	3TF53	3TF54	3TF55	3TF56	3TF57
5000	5000	5000	5000	5000	5000	3000	3000	3000	2000
1,000	1,000	1000	1000	1000	1000	1000	1000	1000	1000
900	900	800	800	800	750	800	750	700	500
400	350	400	300	300	250	300	250	200	170
1000	850	1000	750	700	500	700	500	500	420
300	300	300	200	200	130	200	130	150	150
50		50		50		50		50	50/60 Lower ⁷⁾ Upper ⁷⁾
330		550		910		1430		2450	1136 1900
0.5		0.45		0.38		0.34		0.21	1 1
32		39		58		84		115	16 45
0.23		0.24		0.26		0.24		0.33	0.34 0.16
420		500		876 ⁶⁾		1216 ⁶⁾		1306 ⁶⁾	1110 ⁶⁾
2.7		2.7		11 ⁶⁾		13.3 ⁶⁾		14 ⁶⁾	24 ⁶⁾
0.8 to 1.1 x Us									
22 - 35		22 - 37		25 - 50		25 - 40		25 - 40	48 - 70
5 - 30		8 - 30		10 - 30		10 - 30		8 - 30	80 - 100
32 - 40		28 - 32		32 - 45		36 - 45		40 - 55	44 - 60
95 - 105		185 - 195		10 - 20		10 - 20		10 - 20	12 - 15
10				10				10	
10				10				10	
6				6				6	
3.6				3.6				3.6	
2.5				2.5				2.5	
10				10				10	
3.2				3.2				3.2	
0.9				0.9				0.9	
0.33				0.33				0.33	
10				10				10	
5				5				5	
1.14				1.14				1.14	
0.48				0.48				0.48	
0.13				0.13				0.13	
		16 to 70	35 to 95	35 to 95	50 to 240	50 to 240	50 to 240	50 to 240	50 to 240
		15	20	20	25	25	25	25	30
		3 to 2/0							
		6 to 8	10 to 14	10 to 14	14 to 24	14 to 24	14 to 24	14 to 24	14 to 24
2 x (0.5 to 1, 1 to 2.5), 1 x 4 2 x (0.75 to 2.5) 1 x (1 to 2.5) 2 x (18 to 12) 0.8 to 1.4				2 x (0.5 to 1, 1 to 2.5) 2 x (0.75 to 2.5) 1 x (1 to 2.5) 2 x (18 to 12) 0.8 to 1.4				2 x (0.5 to 1, 1 to 2.5) 2 x (0.75 to 2.5) 1 x (1 to 2.5) 2 x (18 to 12) 0.8 to 1.4	
250	250	400	400	400	400	500	500	800	800
160	160	200	250	250	250	400	400	500	500

8) The opening time delay increases when the contactor coil is protected against voltage peaks. (e.g. Varistor: +2 to +5ms)

Electrical Life Curves

3TF30 to 3TF49 contactors

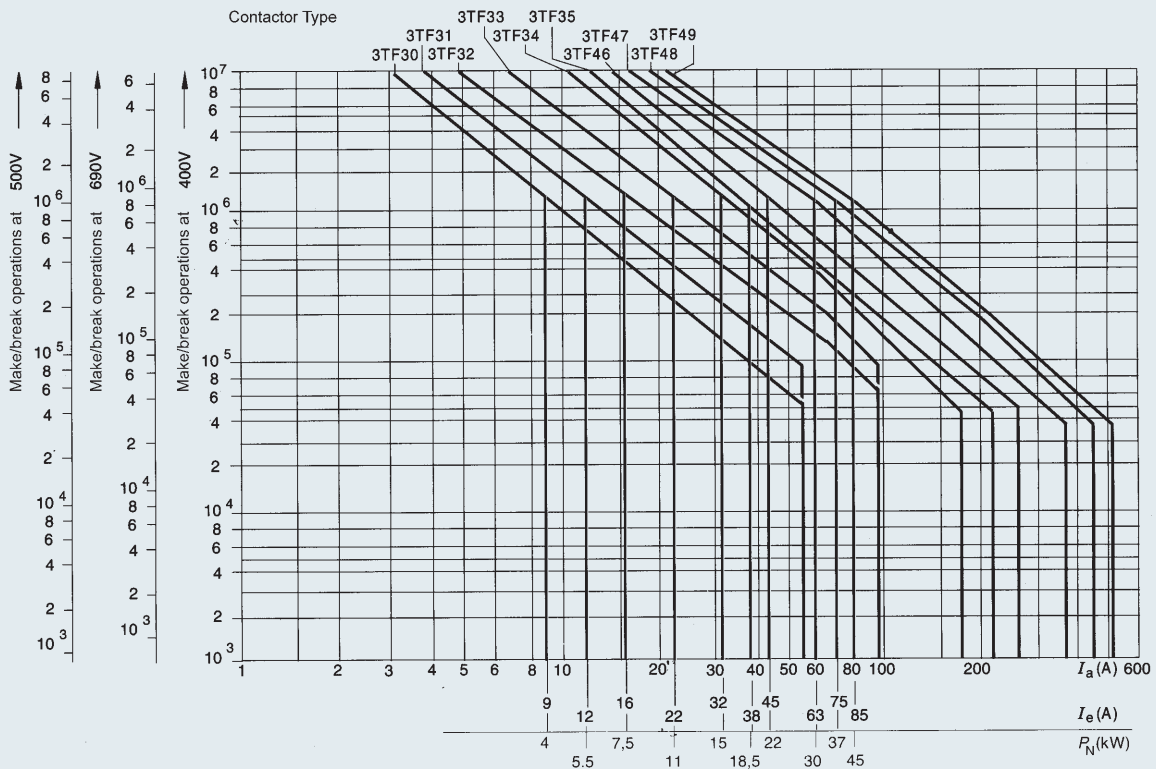

3TF50 to 3TF57 contactors

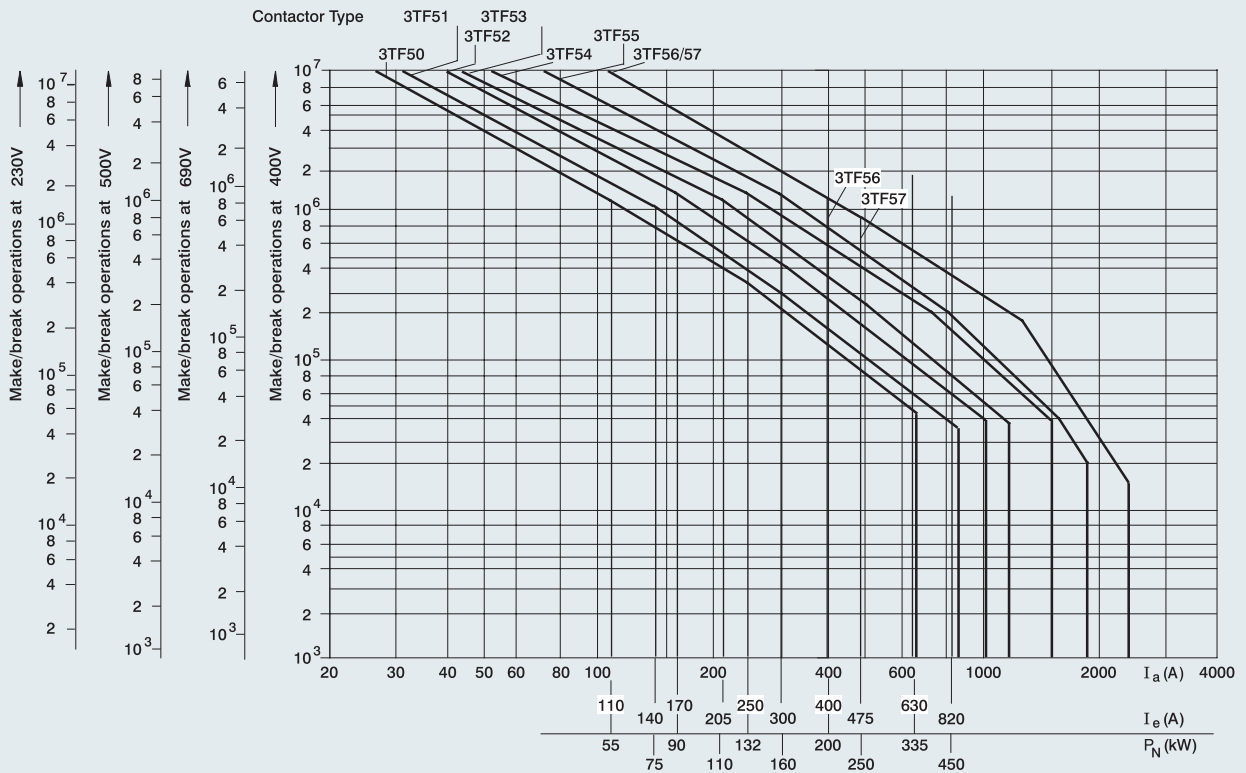

Typical Circuit Diagrams

Direct On Line starter

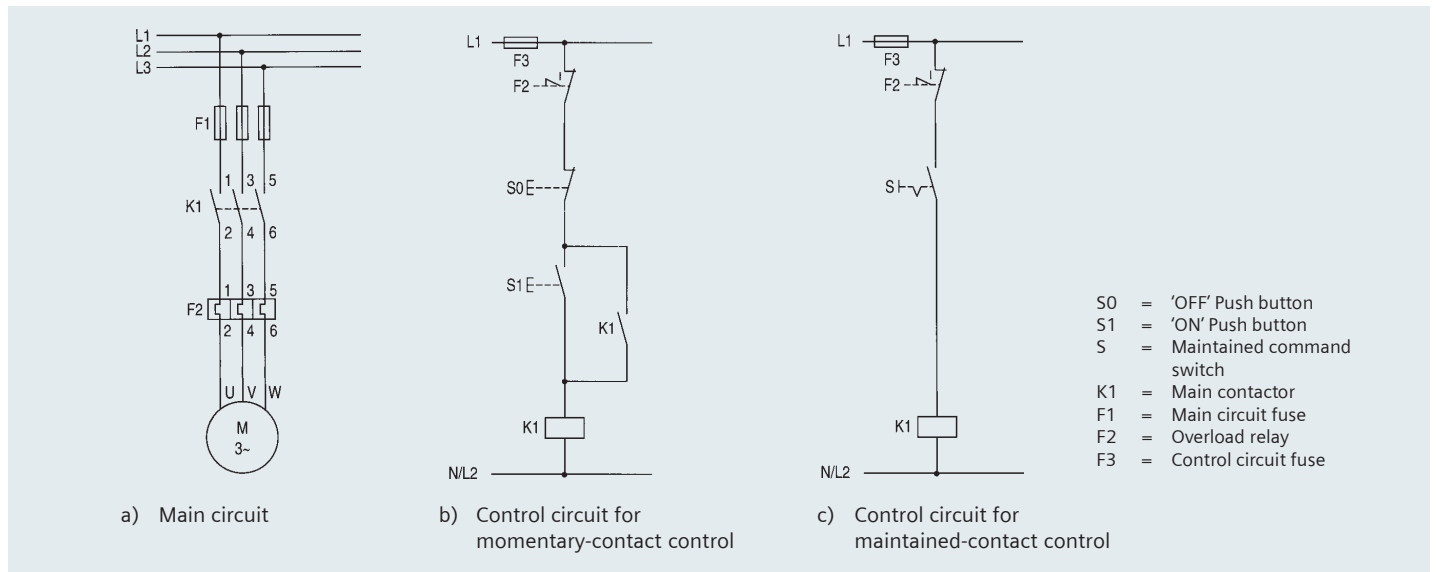

Forward / Reverse starter (Electrical Interlocking)

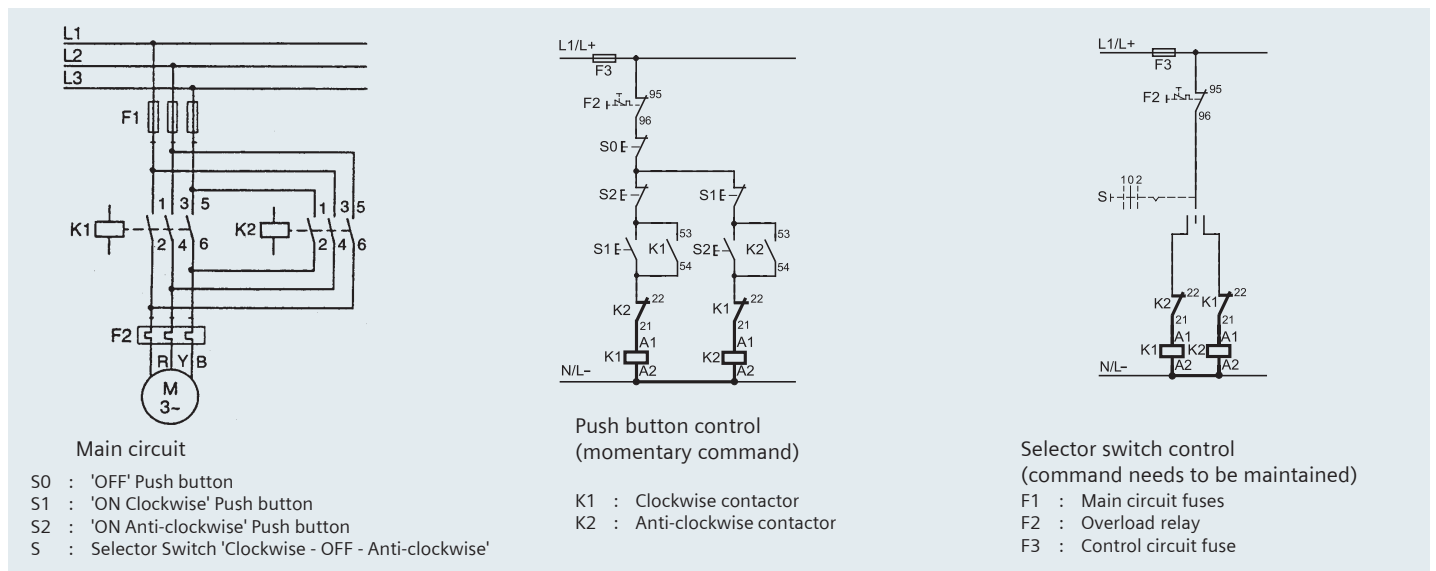

Star Delta starter

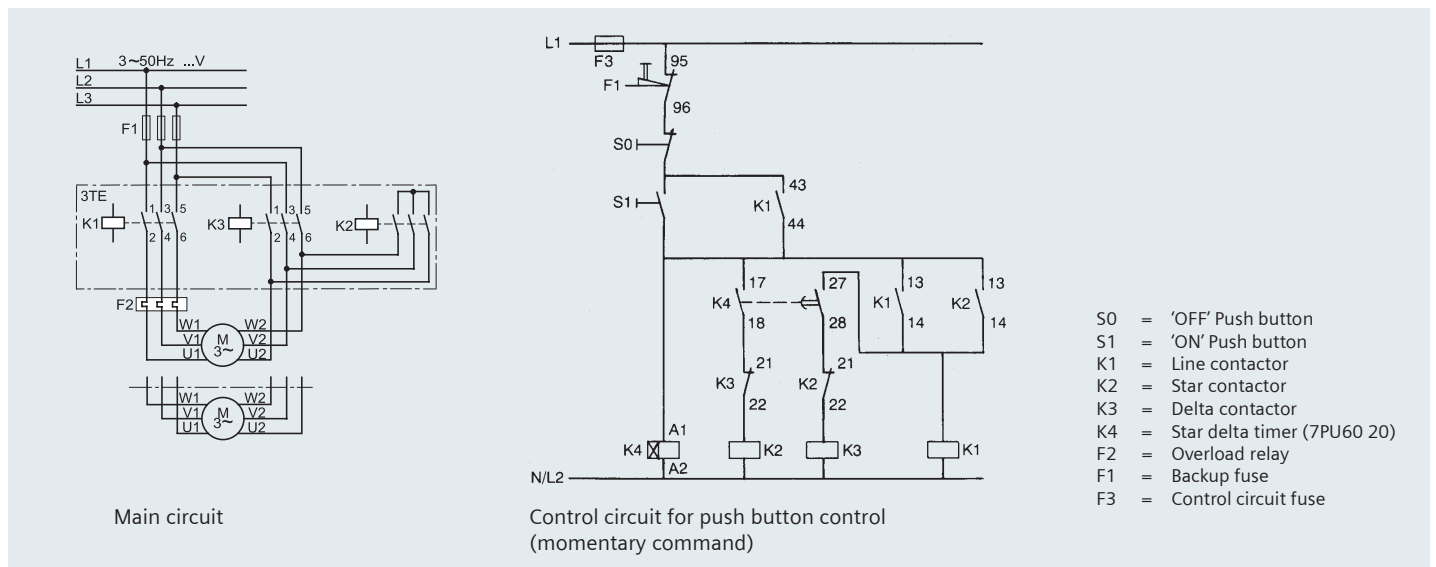

Auto Transformer starter

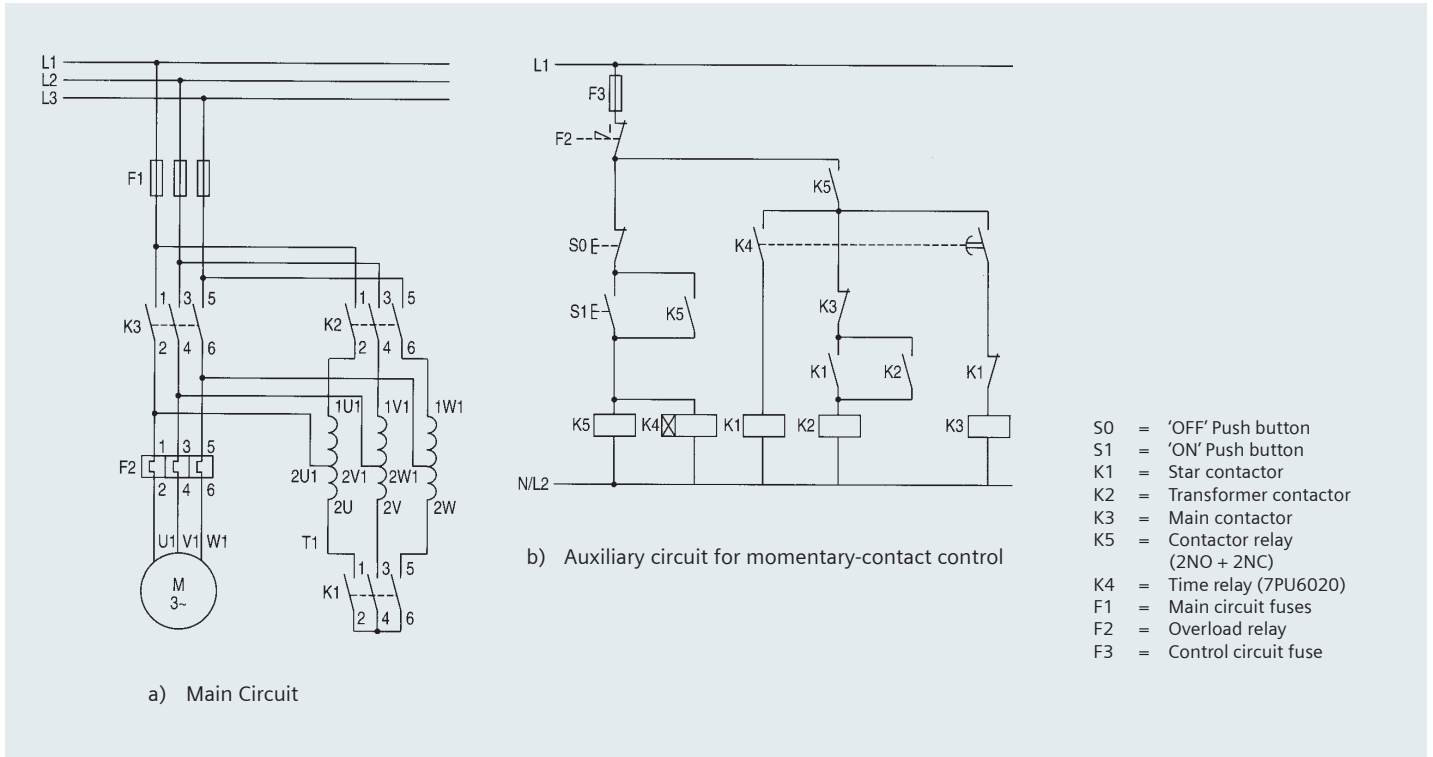

Please refer page no. 70 for selection of switchgear for autotransformer starting method

Internal connection diagram for DC coil circuits

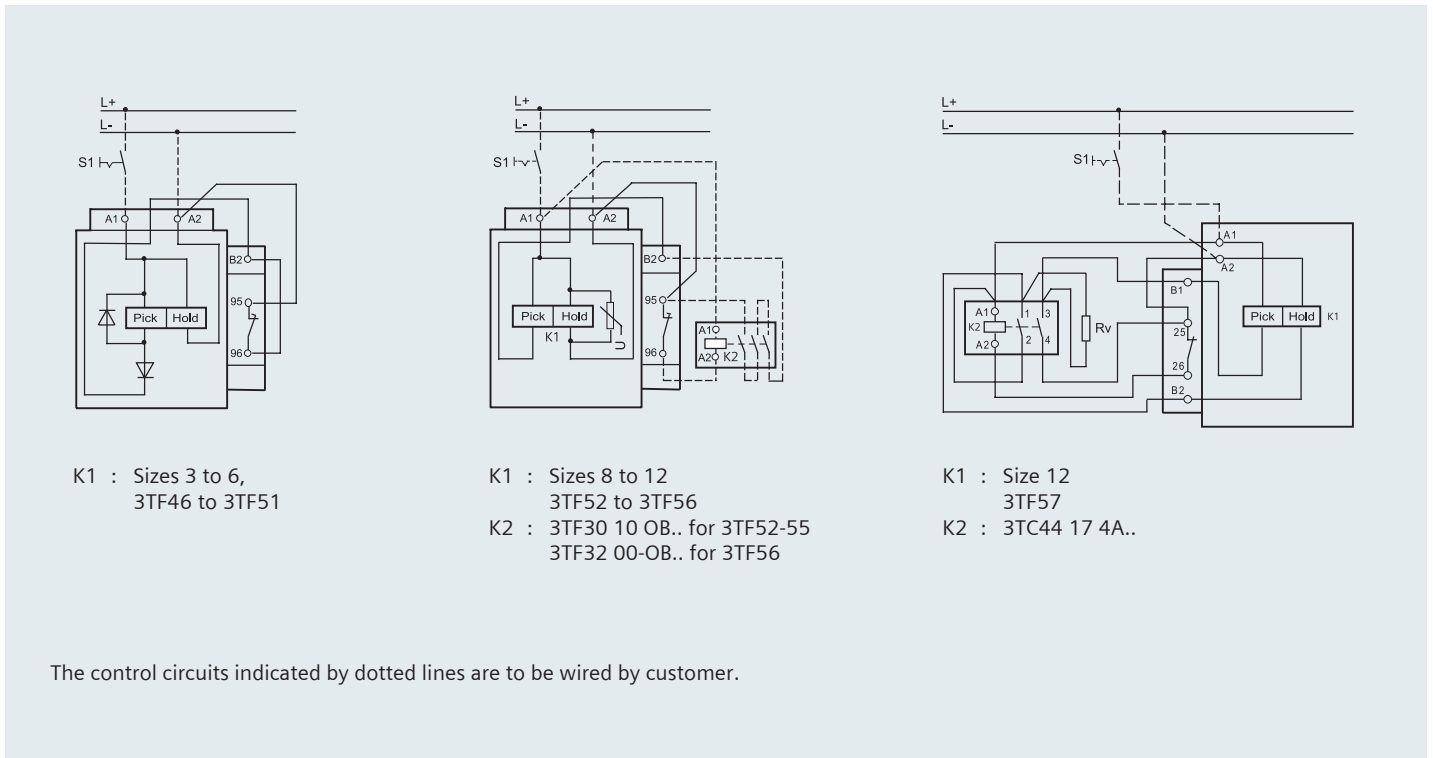

Terminal Designation

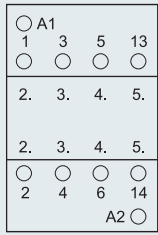

1 NO

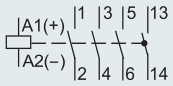

Size 0, 3TF30/31
AC and DC Coil

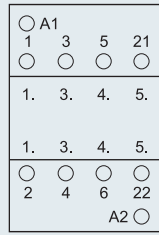

1 NC

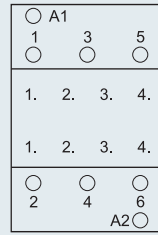
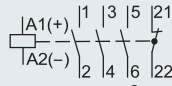

Size 2, 3TF32/33/34/35
AC and DC Coil

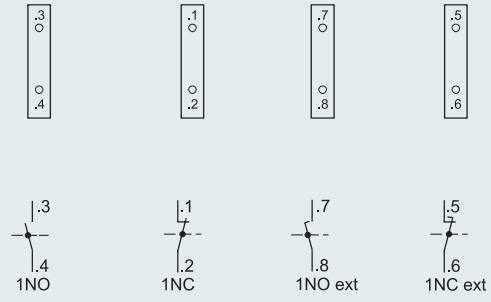
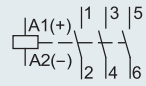

Add-on contact block for 3TF30/31/32/33

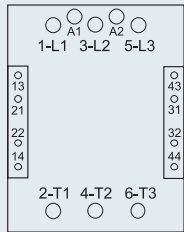

Size 3 to 12, 3TF46 to 3TF57
AC Coil

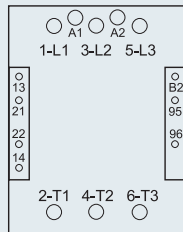
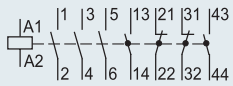

Size 3 to 12, 3TF46 to 3TF56
DC Coil

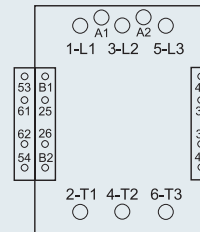
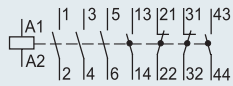

Size 12, 3TF57
DC Coil

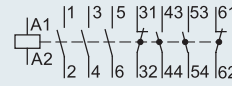

Permissible Mounting Position

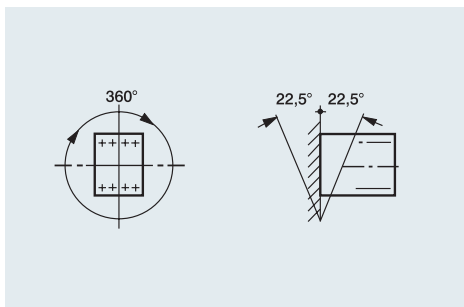

3TF30 to 3TF33 - AC operation

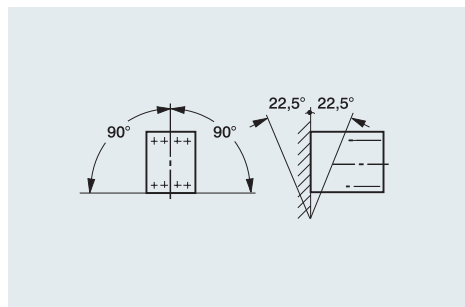

3TF30 to 3TF33 - DC operation
3TF34 to 3TF57 - AC operation
3TF46 to 3TF57 - DC operation

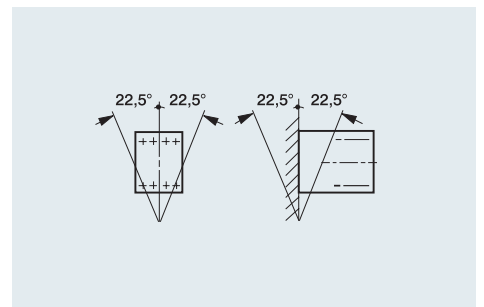

3TF34/35 - DC operation

Accessories and ordering data

1. Mechanical interlocking kit

Mechanical interlock is required when the supply from two different sources is available. Also the same is required for the application involving reversing of motor. Here two contactors are mechanically interlocked with the help of mechanical interlock kit. This ensures closing of only one contactor at a time. Thus prevents a short circuit upon load changeover from one contactor to another.

For Contactor		MLFB	Std. pkg. (nos.)
AC3 Rating	Contactora		
9 to 38A	3TF30 to 35	3TX4 091-1A #	10
45/63/70A	3TF46/47/47-7	3TX7 466-1YA0	2
75/85A	3TF48/49	3TX7 486-1YA0	2
110/140A	3TF50/51	3TX7 506-1YA0	2
170/205A	3TF52/53	3TX7 526-1YA0	2
250/300A	3TF54/55	3TX7 546-1YA0	2
400 A	3TF56	3TX7 566-1YA0	2
110/170 A	3TF50/52	3TX7 526-1YA09	1
170/250 A	3TF52/54	3TX7 546-1YA09	1

#: W/O base plate (not required)

2. Surge suppressor

It is used to reduce the effect of switching overvoltages created during the opening of inductive circuits. Typically they are mounted outside the body of the contactor, and are connected in parallel with the coil terminals. Various techniques for the suppression of switching overvoltages can be employed. For example: RC element, Varistor etc.

RC Element:

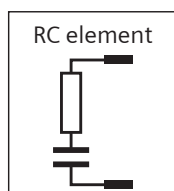

The effective increase in the capacitance of the coil circuit reduces the amplitude and rate of rise of switch off overvoltage spikes to such an extent that no rapid restriking occurs.

Varistor:

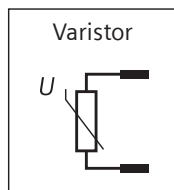

Varistor limits the maximum value of the overvoltage because they become highly conductive above a threshold value. Until this threshold value is reached, no discharge occurs for a small duration.

Selection table:

Surge suppressor (Varistor) for 3TF30-3TF35

Coil Voltage		Type	Std. pkg. (nos.)
AC	DC		
24 - 48 V	24 - 70V	3TX7 402-3GY1	10
48 - 127V	70 - 150V	3TX7 402-3HY1	
127 - 240V	150 - 250V	3TX7 402-3JY1	
240 - 400V	–	3TX7 402-3KY1	
400 - 600V	–	3TX7 402-3LY1	

Surge suppressor (Varistor) for 3TF46-56

Coil Voltage		Type	Std. pkg. (nos.)
AC	DC		
Less than 48V	24 - 70V	3TX7 462-3GY1	10
48 - 127V	70 - 150V	3TX7 462-3HY1	
127 - 240V	150 - 250V	3TX7 462-3JY1	
240 - 400V	–	3TX7 462-3KY1	
400 - 600V	–	3TX7 462-3LY1	

Surge suppressor (RC Element) for 3TF30-3TF35

Coil Voltage		Type	Std. pkg. (nos.)
AC	DC		
24 - 48V	24 - 70V	3TX7 402-3RY2	10
48 - 127V	70 - 150V	3TX7 402-3SY2	
127 - 240V	150 - 250 V	3TX7 402-3TY2	
240 - 400V	–	3TX7 402-3UY2	
400 - 460V	–	3TX7 402-3VY2	

3. Connector

The 3TS90 connector is used to mount the motor protection circuit breaker 3VU on the contactor 3TF with screw terminals. It enables mechanical and electrical connection between contactor and motor protection circuit breaker.



Range:

Size of connector	MPCB		Contactor		MLFB of Connector	Std. pkg. (nos.)
	MLFB	Current Rating	MLFB	AC3 Current Rating		
I	3VU13	0.16 to 20A	3TF30 / 31	9 / 12 A	3TS90 01-8K	1
II	3VU13	6 to 25A	3TF32 / 33	16 / 22A	3TS90 02-8K	1

Benefits:

Direct mounting of 3VU MPCB on 3TF contactor eliminates the need of power wiring and ensures secure connection. In addition, the assembly time and size of the feeder is reduced which results in cost saving. The overall assembly also looks contemporary.

Spares and ordering data

1. Auxiliary Contact Blocks

In-built contact configuration

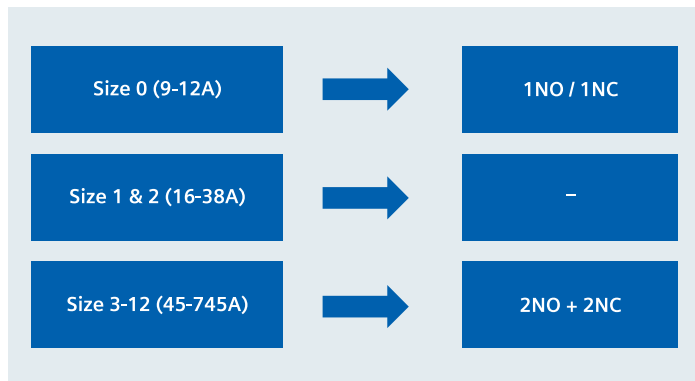

Add – on Contact Blocks:

For Contactor	Add on contact blocks	Type	Std. pkg. (nos.)
3TF30-35	1NO 1NC 1NO ext 1NC ext	3TX40 10-2A 3TX40 01-2A 3TX40 10-4A 3TX40 01-4A	10
3TF46-57	1NO+1NC Left 1NO+1NC Right 1NO + 1NC (Extd) Right	3TY7 561-1A 3TY7 561-1B 3TY7 561-1E	1
3TF46-57	Second 1NO+1NC Left Second 1NO+1NC Right	3TY7 561-1K 3TY7 561-1L	1
3TF46/47/477	Special block for DC Coil Circuit	3TY7 461-1F	1
3TF48 to 57	Special block for DC Coil Circuit	3TY7 481-1F	1

2. Main contact kits / arc chambers / AC-DC coils

For contactor type (AC3 rating)	Main contact kits (6 fixed & 3 moving contacts)	Arc chambers	AC coils ¹⁾	DC coils ¹⁾	Std. pkg. (nos.)
3TF30 (9A)	-	-	3TY7 403-0A..	3TY4 803-0B..	1
3TF31 (12A)	-	-			
3TF32 (16A)	3TY7 420-0A	-			
3TF33 (22A)	3TY7 430-0A	-			
3TF34 (32A)	3TY7 340-0C	3TY7 342-0C	3TY7 443-0A..	3TY7 443-0B..	
3TF35 (38A)	3TY7 350-0C	3TY7 352-0C			
3TF46 (45A)	3TY7 460-0YA	3TY7 462-0YA	3TY7 463-0A..	3TY7 463-0D..	
3TF47 (63A)	3TY7 470-0YA	3TY7 472-0YA			
3TF477 (70A)	3TY7 477-0YA	3TY7 477-0YD			
3TF48 (75A)	3TY7 480-0A	3TY7 482-0A	3TY7 483-0A..	3TY7 483-0D..	
3TF49 (85A)	3TY7 490-0A	3TY7 492-0A			
3TF50 (110A)	3TY7 500-0YA	3TY7 502-0YA	3TY7 503-0A..	3TY7 503-0D..	
3TF51 (140A)	3TY7 510-0YA	3TY7 512-0YA			
3TF52 (170A)	3TY7 520-0YA	3TY7 522-0YA	3TY7 523-0A..	3TY7 523-0D..	
3TF53 (205A)	3TY7 530-0YA	3TY7 532-0YA			
3TF54 (250A)	3TY7 540-0YA	3TY7 542-0YA	3TY7 543-0A..	3TY7 543-0D..	
3TF55 (300A)	3TY7 550-0YA	3TY7 552-0YA			
3TF56 (400A)	3TY7 560-0YA	3TY7 562-0YA			
3TF57 (475A)	3TY7 570-0YA	3TY7 572-0YA	3TY7 573-0C	3TY7 573-0D..	

¹⁾ Please fill in coil voltage code from table below

Coil voltage code AC 50Hz: 3TF30 to 3TF56

Coil voltage	24	42	110	230	415
Code	B0	D0	F0	P0	R0

Coil voltage code DC: 3TF30 to 3TF57

Coil voltage (V)	24	42	48	110	220	250 ⁺
Code	B4	D4	W4	F4	M4	N4

⁺ For 3TF3 only

Coil voltage code AC 50/60 Hz: 3TF57

Coil voltage (V)	110-132	220-240	380-460
Code	F7	M7	Q7

(Other coil voltages are also available)

Dimensional drawing

3TF30/31 AC Coil

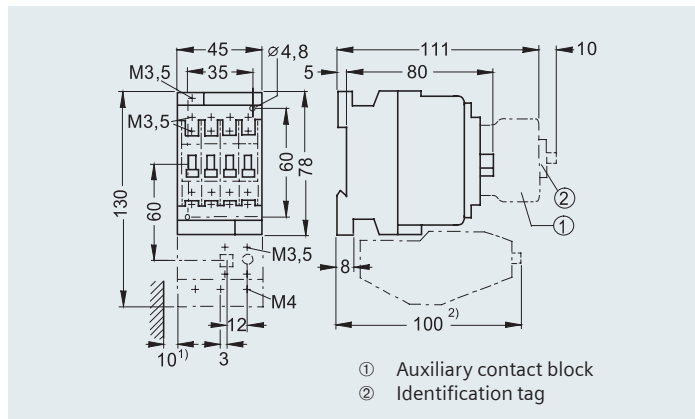

3TF30/31 DC Coil

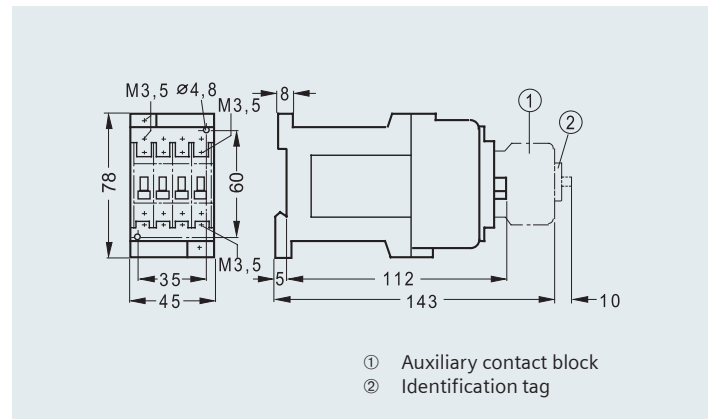

3TF32/33 AC Coil

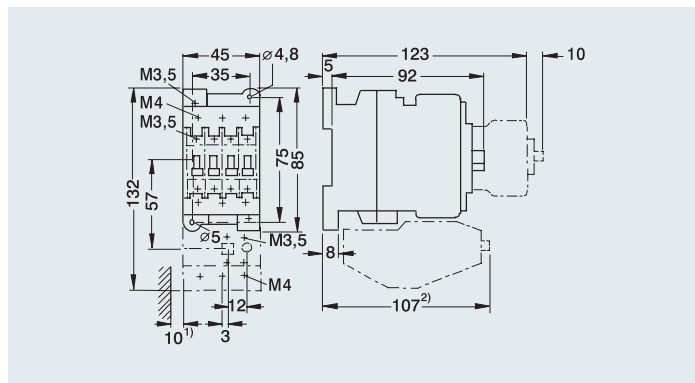

3TF32/33 DC Coil

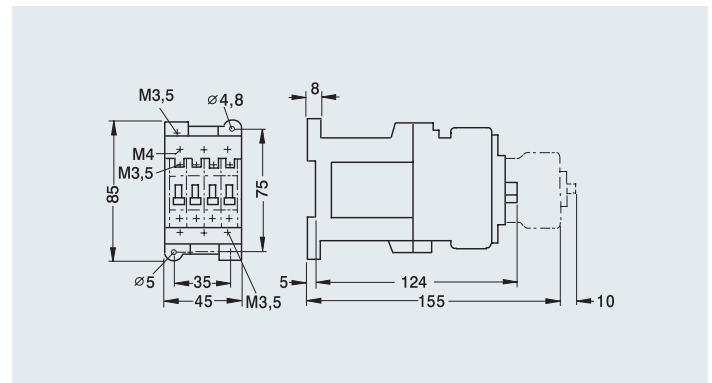

3TF34/35 AC Coil

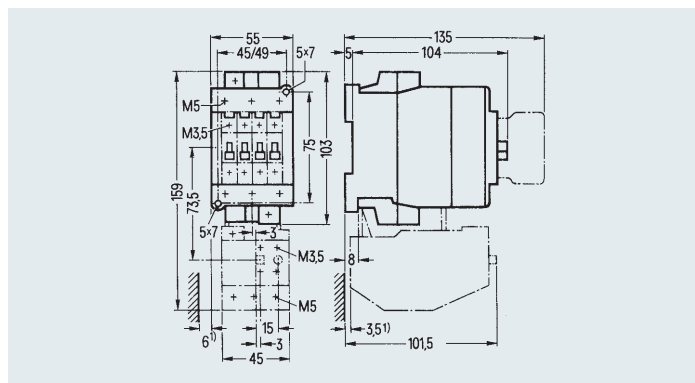

3TF34/35 DC Coil

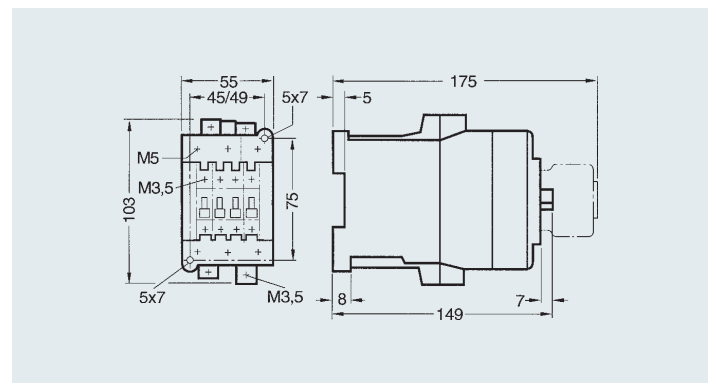

3TF30 to 3TF32, with mechanical interlock kit

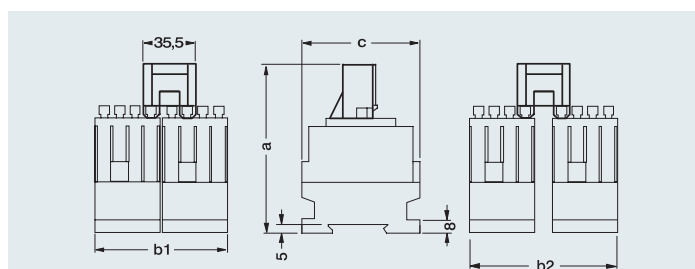

Type	a (AC coil)	a (DC coil)	b1	b2	c
3TF30/31	116	148	90	100	78
3TF32/33	127	159	91	101	85

Notes

- Dimensions for coil terminals
- Dimensions for mounting terminals
Minimum clearance from insulated components = 5mm
Minimum clearance from earthed components = 10mm
- size of power terminals
- Size of auxiliary terminals

3TF46 and 3TF47

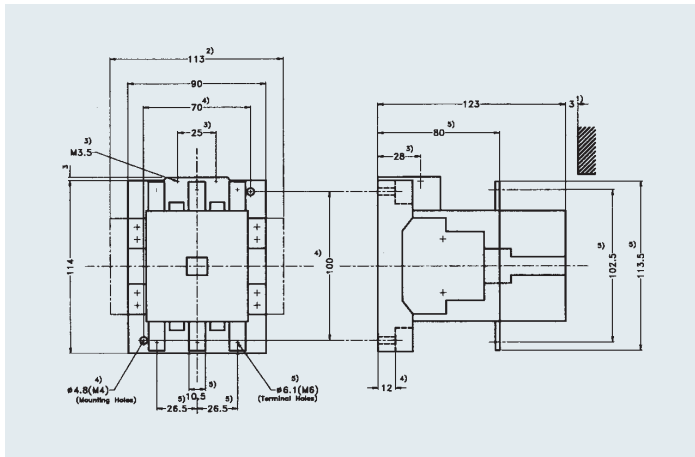

3TF47 7

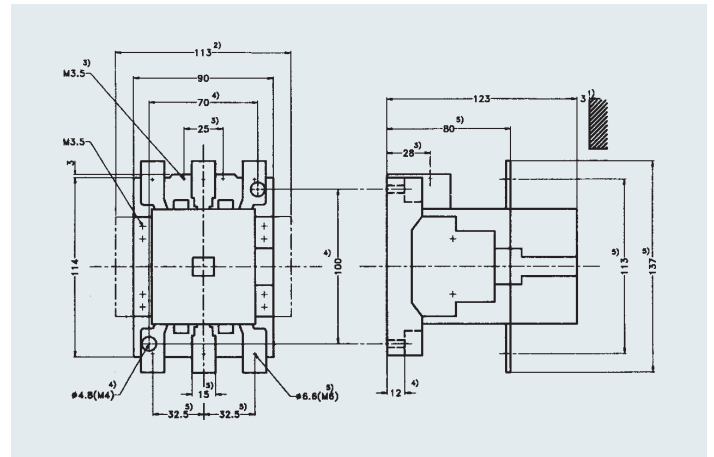

3TF48 and 3TF49

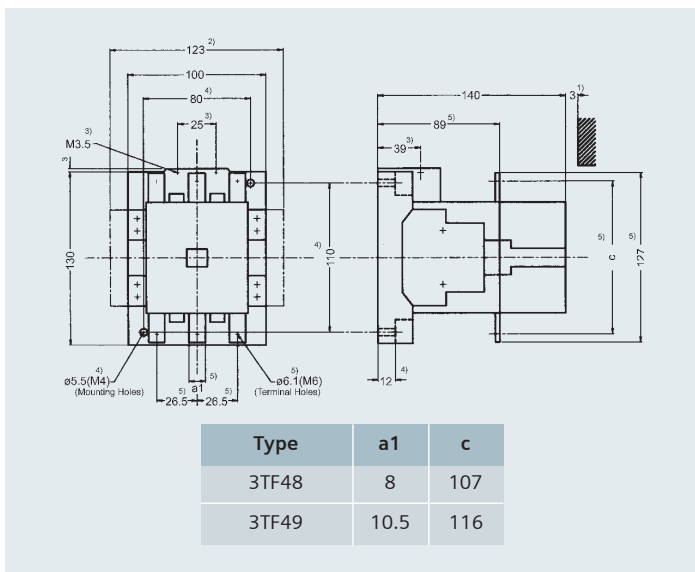

Type	a1	c
3TF48	8	107
3TF49	10.5	116

3TF50 and 3TF51

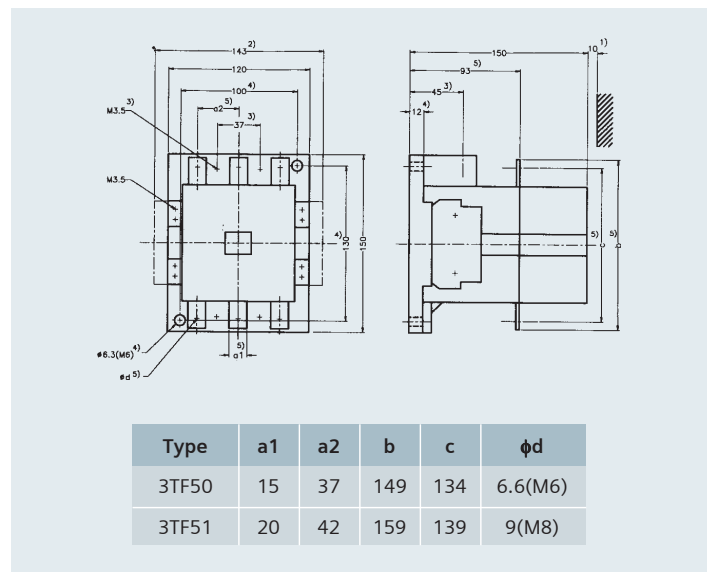

Type	a1	a2	b	c	ϕd
3TF50	15	37	149	134	6.6(M6)
3TF51	20	42	159	139	9(M8)

3TF52 and 3TF53

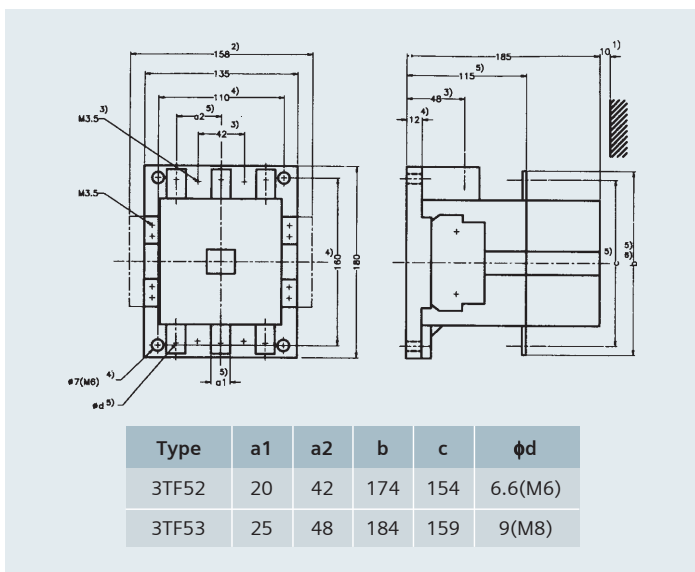

Type	a1	a2	b	c	ϕd
3TF52	20	42	174	154	6.6(M6)
3TF53	25	48	184	159	9(M8)

3TF54/55

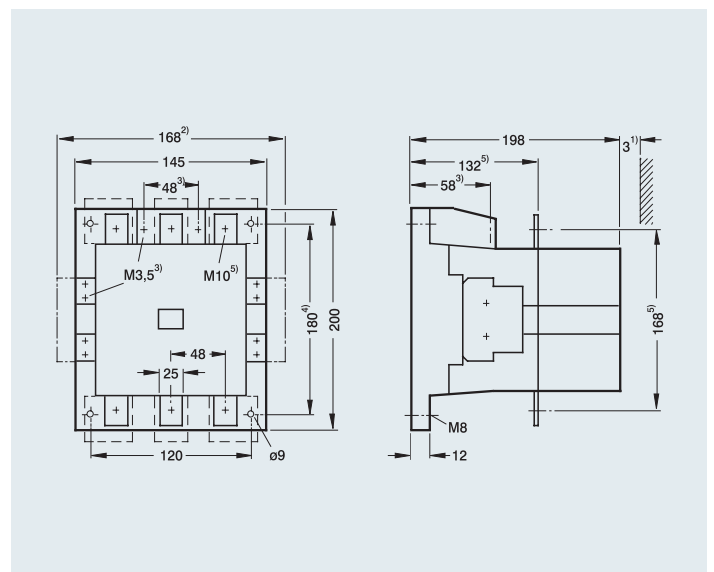

Notes

- 1) Minimum clearance from insulated components = 3mm
Minimum clearance from earthed components = 10mm
- 2) Dimension with second auxiliary contact block on both sides
- 3) Dimension for coil terminal.

- 4) Dimension for mounting.
- 5) Dimension for power terminal.
- 6) 3TF53 The conductor bars protrude over the contactor edges on top and bottom by 2mm each.

3TF56/57

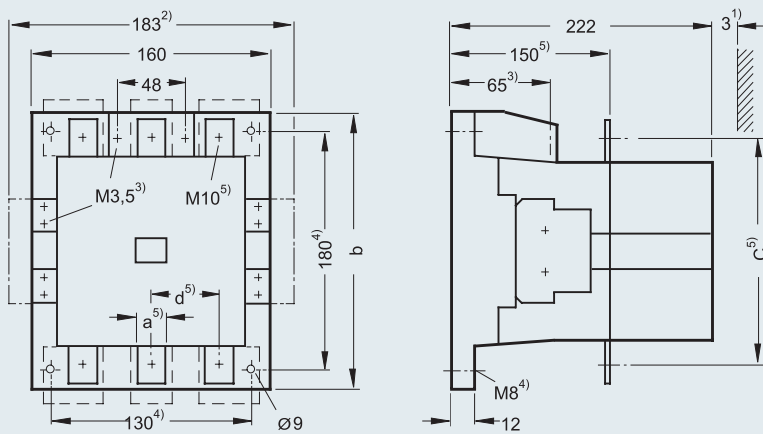

Type	a	b	c	d
3TF56	25	200	178	48
3TF57	30	209.5	182	52

3TF46/47/477/48/49 with Mechanical Interlock Kit

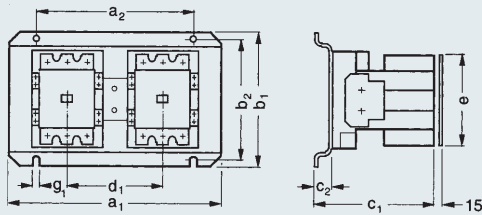

For Contactor	a ₁	a ₂	b ₁	b ₂	c ₁	c ₂	d ₁	e	g ₁
3TF46/47/477	240	180	165	145	141	18	117	150	7 (M6)
3TF48/49	260	200	175	155	158	18	127	160	7 (M6)

3TF50 to 3TF57 with Mechanical Interlock Kit

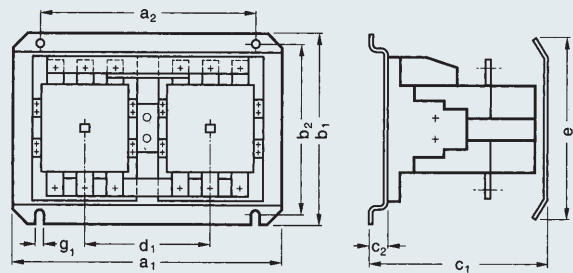

For Contactor	a ₁	a ₂	b ₁	b ₂	c ₁	c ₂	d ₁	e	g ₁
3TF50/51	300	240	210	185	160	18	147	260	9 (M8)
3TF52/53	330	270	240	215	203	18	162	315	9 (M8)
3TF54/55	350	290	265	240	219	21	172	375	11 (M10)
3TF56/57	380	310	265	240	243	21	187	385	11 (M10)

3TF50 and 3TF52 with Mechanical Interlock Kit 3TF52 and 3TF54 with Mechanical Interlock Kit

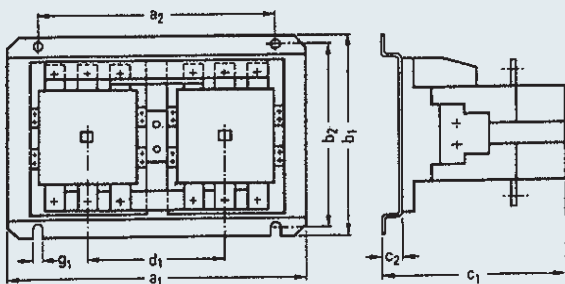

Type	a ₁	a ₂	b ₁	b ₂	c ₁	c ₂	d ₁	g ₁
3TF52 & 50	330	270	240	215	203	18	154.5	11
3TF54 & 52	350	290	265	240	219	21	167	11

Notes

- 1) Minimum clearance from insulated components = 3mm
Minimum clearance from earthed components = 10mm
- 2) Dimension with second auxiliary contact block on both sides
- 3) Dimension for coil terminal.
- 4) Dimension for mounting.
- 5) Dimension for power terminal.

Useful information

Categories of duty - as per IEC 947 / IS 13947

Current	Utilisation Categories	Typical Application
AC	AC1	Non-inductive or slightly inductive loads, resistance furnaces
	AC2	Slipping motors; starting, switching off
	AC3	Squirrel-cage motors; starting, switching off motors during running ⁽¹⁾
	AC4	Squirrel-cage motors; starting, plugging, inching
	AC5a	Switching of electric discharge lamp controls
	AC5b	Switching of incandescent lamps
	AC6a	Switching of transformers
	AC6b	Switching of capacitor banks
	AC7a	Slightly inductive loads in household appliances and similar applications
	AC7b	Motorloads for household applications
	AC8a	Hermetic refrigerant compressor motor ⁽²⁾ control with manual resetting of overload releases
AC8b	Hermetic refrigerant compressor motor ⁽²⁾ control with automatic resetting of overload releases	
DC	DC1	Non-inductive or slightly inductive loads, resistance furnaces
	DC3	Shunt-motors: starting, plugging, inching, dynamic braking of d.c motors
	DC5	Series-motors: starting, plugging, inching, dynamic braking of d.c motors
	DC6	Switching of incandescent lamps

- (1) AC3 category may be used for occasional inching (jogging) or plugging for limited time periods such as machine set-up; during such limited time periods the number of such operations should not exceed five per minute or more than ten in a 10-min period.
- (2) Hermetic refrigerant compressor motor is a combination consisting of a compressor and a motor, both of which are enclosed in the same housing, with no external shaft or shaft seals, the motor operating in the refrigerant
- (3) Selection of contactors for utilisation categories from AC-5a to AC-8b and DC6 upon enquiry.

Contact life calculation:

Contactors have bounce free operation. Electrical life is influenced by the breaking currents. For normal AC3 duty the breaking current is the rated operational current and for AC4 duty, the typical breaking current is 6 times the rated operational current. In case of mixed duty, the expected life is determined as under

$$X = \frac{A}{1 + \frac{C}{100} \left(\frac{A}{B} - 1 \right)}$$

Where

- X = expected life for mixed duty
A = expected life for normal AC3 duty
B = expected life for 100% AC4 duty
C = proportion of inching operations as a percentage of total operations.

Recommended selection of contactors for hoisting duty (upto 85A)

In hoisting operation, slipping motors are generally used. For this typical hoisting duty, we recommend the contactors listed in the following table.

Contactor Type	Stator Protection Maximum load current with hoisting motor. For intermittent duty S3				Rotor Protection Maximum load current with hoisting motor(Delta circuit). For intermittent duty S3				Max rotor standstill voltage
	25%	40%	60%	100%	25%	40%	60%	100%	
	A	A	A	A	A	A	A	A	V
3TF31	10	10	9	8	15	14	13	12	660
3TF33	17	16	15	13	25	24	22	20	660
3TF45	28	25	23	20	42	38	35	30	660
3TF47	49	45	40	30	73	68	60	45	750
3TF49	68	62	54	45	100	95	80	68	1000

Recommended substitutes for discontinued 3TA/3UA19

For standard application (AC3 duty)

AC3 rating 415V, 50Hz	Size	Discontinued contactor	Discontinued bi-relay	Size	Contactor	Bi-relay	Motor kW 415V, 50Hz, 3ph.
7.8A	1	3TA67 3TA76	3UA1911	0	3TF30	3UA5000	3.8
9A		3TA21					4
12A							5.5
16A							7.5
22A	2	3TA11	3UA1928	1	3TF32 3TF33	3UA5200	11
30A		3TA22					15
32A	4	3TA13	3UA1938	2	3TF34 3TF35	3UA5500*	18.5
38A							20
45A	8	3TA24 ¹⁾	3UA1938	3	3TF46-Z 3TF47-Z 3TF47-7	3UA5800-Z1	22
63A							30
70A							37
105A	8	3TA16	3UA66	4	3TF48/49	3UA5800-Z1	45
110A							55
140A	8	3TA28-Y	3UA66	6	3TF50 3TF51	3UA5830	75
170A							95
200A	12	3TA28	3UA66	8	3TF52 3TF53	3UA6230	110
250A							132
300A	12	3TB56	3UA66	10	3TF54 3TF55	3UA6230	160
400A							220
475A	-	-	-	12	3TF56 3TF57	3UA6830	250

use 3UA50 + 3UX1418 to replace 3UA19 28 (upto 12A) use 3UA52 + 3UX1420 to replace 3UA19 28 (upto 25A)

¹⁾ For crane/hoisting/inching application, replace 3TA24 with 3TF48/49 contactors

For inching application (AC4 duty)

Discontinued contactor		New contactor	
Size	Type 3TA	Size	Type 3TF
1	3TA21	1	3TF32
1	3TA11	1	3TF33
2	3TA22	2	3TF34
2	3TA13	2	3TF35
4	3TA24	4	3TF48
4	3TA16	6	3TF50
8	3TA28	8	3TF52
12	3TB56	12	3TF56

Adaptor plate for replacing 3TA

Adaptor plates, to replace	Type
3TA61-0A by 3TH80/82-0A	3TX6 406-0A
3TA67/21 by 3TH80/82 3TA67/21 by 3TF30/31 & 3TA21/11 by 3TF32/33	3TX21 43 1YA0
3TA22/13 by 3TF32/33/44/45	3TX22 42 1YA0
3TA24 by 3TF46/47/477	3TX24 46 1YA0
3TA24/16 by 3TF48/49	3TX16 48 1YA0
3TA16 by 3TF50/51	3TX16 50 1YA0
3TA28 by 3TF50/51	3TX28 50 1YA0
3TA28 to 3TF52/53	3TX28 52 1YA0

For crane application (AC2 duty, S3 100% inching)

Discontinued contactor		New contactor	
Size	Type 3TA	Size	Type 3TF
1	3TA21/11	1	3TF33
2	3TA22/13	2	3TF35
4	3TA24	4	3TF49
8	3TA28	8	3TF5200*
12	3TB56	12	3TF5600*

* Hoisting duty contactors, designed specially for hoisting duty.

Contactors for Hoisting Duty

AC slipring motors are most commonly used for the hoisting applications. AC2 duty pertains to starting and switching off the slipring motors. In case of hoisting duty breaking current is the starting current and frequency of switching is high.

The table shows the making and breaking capacity at normal and at hoisting application where I_e indicates the rated full load current.

	Making	Breaking
During Normal operation at full load	$2.5 * I_e$	I_e
Hoisting application at full load	$2.5 * I_e$	$2.5 * I_e$
During Normal operation at partial load	less than $2.5 * I_e$	Less than I_e

Application

AC-2 operation is the typical duty for starting and switching off fully-loaded slipring motors in the starting phase. The rating of the contactor, to switch the motors, is selected primarily on the basis of rated make & break capacity and desired electrical endurance.

Standard

The contactors comply with the "Regulations to low voltage switchgear" of DIN VDE 0660 and IEC 60947-4-1.

Range

Hoisting duty contactors are available from 110A to 400A (AC2/AC3 rating).

Benefits and features

Long life

- "Hoisting Duty" Contactors are provided with new design of contacts ($AgSnO_2$ instead of $AgCdO$) resulting in **high electrical and mechanical life**.
- They are electrically superior in taking care of excessive stresses coming on contactors during their operations in crane applications.

Reliability

- The "Hoisting Duty" Contactors have vacuum impregnated coils which are suitable for high frequency switching and high vibrations. This helps in reducing coil failures.
- Side mounted auxiliary contact blocks are screw mounted and not snap fitted to withstand vibrations and high frequency operation.



Operator safety

- **Arc Chamber Interlock**
It prevents the contactor from switching ON, if the arc chamber is not fitted properly. Thus avoids accidents to plant and personnel.
- **Finger touch proof terminals**
It protects against accidental contact with live parts which ensures operator safety.

High performance

- **No derating upto 55°C**
Contactors are suitable for operation in service temperature upto 55°C without derating. This avoids selection of higher rated contactor, thereby reducing cost.

Selection and ordering data

Hoisting duty contactors – For high switching frequency / inching applications with AC coils, 2NO+2NC aux. contacts

Contactor size	Rated current I_e (A) AC2/AC3 at 415V	Type	Std. pkg. (nos.)
6	110	3TF50 00-0A..	1
8	170	3TF52 00-0A..	
10	250	3TF54 00-0A..	
12	400	3TF56 00-0A..	

Coil voltages:

Coil voltage - 50Hz	110V	230V	415V
Code	F0	P0	R0

(Other coil voltages are also available)

Technical Information

A. Recommended selection of contactors for hoisting duty

In hoisting operation, slipping motors are generally used. For this typical hoisting duty, we recommend the contactors listed in the following table.

Contactor Type	Stator Protection Maximum load current with hoisting motor. For intermittent duty S3				Rotor Protection Maximum load current with hoisting motor(Delta circuit). For intermittent duty S3				Max rotor standstill voltage
	25%	40%	60%	100%	25%	40%	60%	100%	
3TF50 00 0A	100	88	78	65	150	130	115	95	1000
3TF52 00 0A	145	130	115	95	220	195	170	150	1000
3TF54 00 0A	225	200	180	160	340	300	270	240	1000
3TF56 00 0A	355	325	290	250	530	490	435	375	1000

When 3 conducting paths are connected in parallel, the maximum load current rises to 2.5 times the value given in this table. When 2 conducting paths are connected in parallel, it rises to 1.8 times the value given in this table.

B. Selection of contactors for contact endurance: with normal and inching operation

Contactors suffer more erosion during inching operation than when stopping motors from a steady speed, i.e. normal operation. With slipping motors the starting current can be up to 2.5 times the rated current of the motor which means that this current has to be broken when inching is taking place. During normal operation, on the other hand, only the rated current has to be broken under full-load; under part-load it is even less. Determining contact endurance from AC-2 duty ($I_c = 2.5 \times I_e$) will only give correct results when 100% inching operation is involved.

Max. permissible current and attainable contact endurance when braking starting current given below PF ≥ 0.4 (2.5 x Ie)		Contact life when breaking the stator contactor load currents for S3-100% duty, I _c = I _e , no inching		Contactor Type
A	Operating cycles Approx.	A	Approx. Operating cycles	
275	280,000	65	3,500,000	3TF5000
425	250,000	95	3,100,000	3TF5200
625	250,000	160	2,700,000	3TF5400
1000	150,000	250	2,500,000	3TF5600

The maximum permitted current (e.g. locked-rotor current of motor) must not exceed the values given in the "Max. starting current and attainable contact endurance" column. The values cannot be increased by paralleling pole assemblies.

C. Selection of contactors for contact endurance: with mixed operation

When mixed operation is involved, i.e. primarily breaking of the motor rated current but with some breaking of higher currents due to inching, the endurance of the contacts can be calculated approximately from the following equation:

$$X = \frac{A}{1 + \frac{C}{100} \left(\frac{A}{B} - 1 \right)}$$

Where

X = Contact endurance with mixed operation cycles.

A = Contact endurance with normal operation ($I_a = I_e$) in operating cycles, from Fig. 1.

B = Contact endurance with inching operation ($I_a = \text{Multiple of } I_e$) in operating cycles, from Fig. 2, Breaking current $I_a/AC-2 = 2.5 \times I_e$.

C = Proportion of inching in total operating Cycles in %.

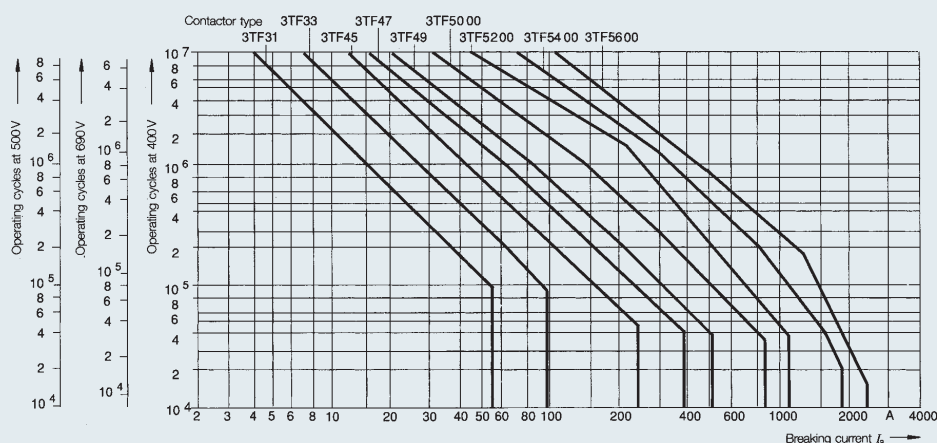

Fig. 1 Contact endurance of 3TF contactors as a function of breaking current when switching resistive and inductive AC loads.

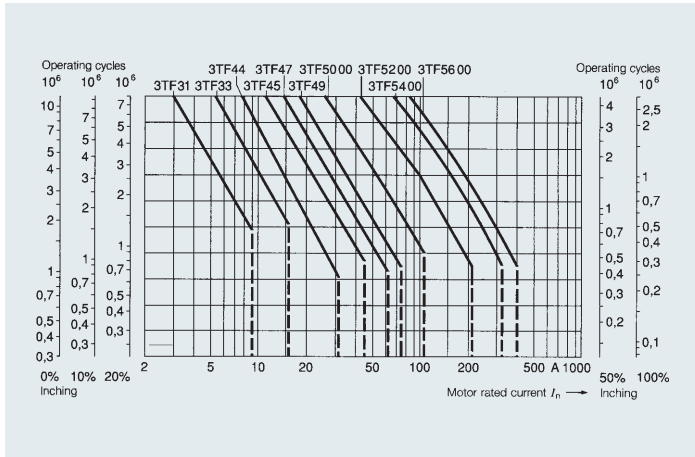

Fig. 2 Contact endurance for mixed operation as a function of motor rated current. Motor on rated load, inching at 2.5 times motor rated current (slipping motor).

The contact endurance as a function of the motor rated current with mixed operation can be determined from Fig. 2 for proportions of inching of 0, 10, 20, 50 and 100%. The values obtained are only applicable if rated motor load is used continuously. In practice therefore, the contact endurance should be greater.

D. NOMOGRAM

Apart from knowing the figure for **contact endurance in operating cycles**, users are also interested to know what **period of time** this amounts to before the contacts have to be changed. The value can be ascertained from the nomogram in Fig. 3. **using the Nomogram**

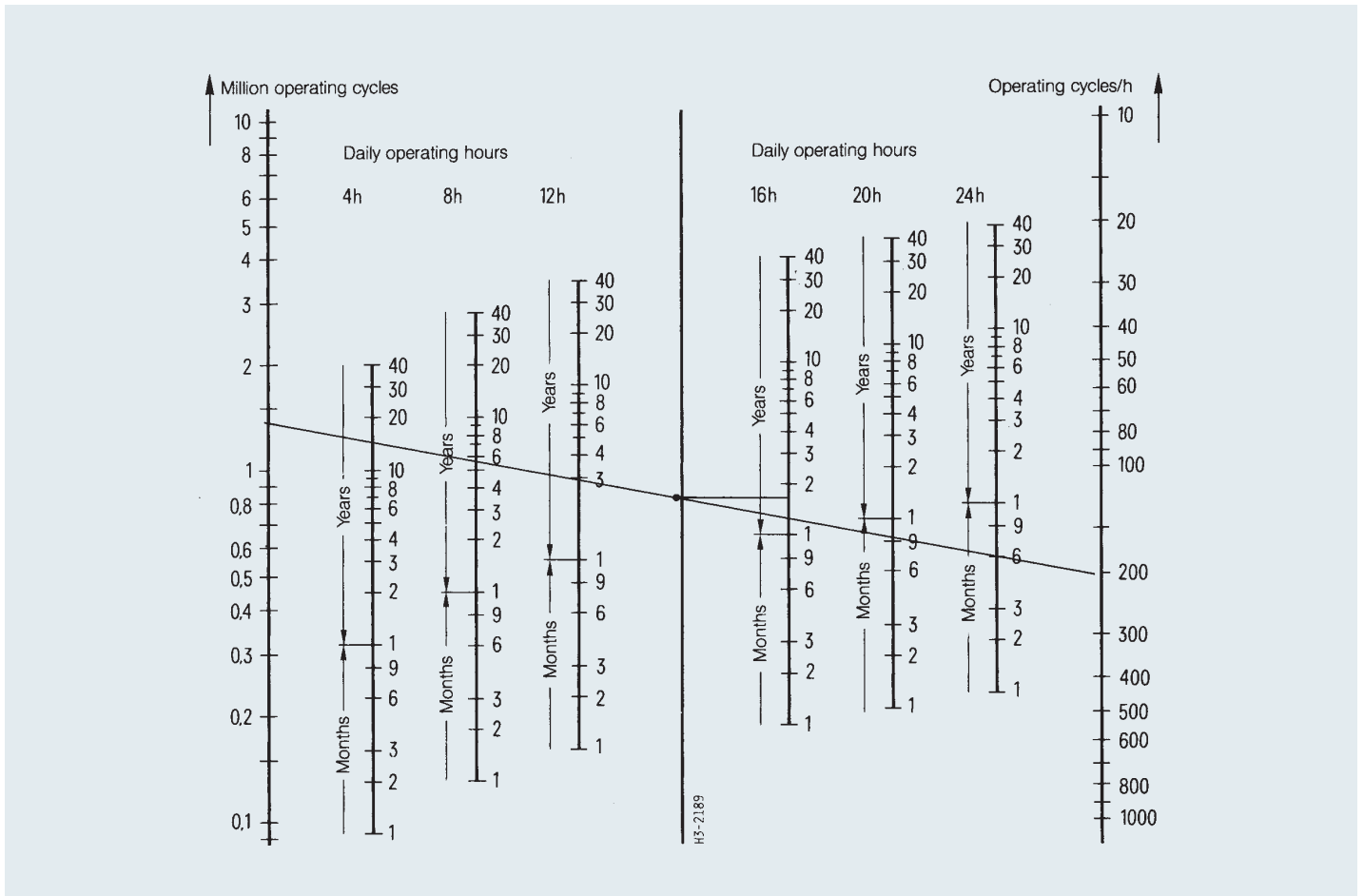

Fig. 3 Nomogram for determining contact endurance in year (250 working days) and months with daily operating hours of 4, 8, 12, 16, 20 and 24 h.

Example 1

Motor rated current 150A. Selected contactor: **3TF5600**

Contact endurance in operating cycles at 400V With inching of				
0%	10%	20%	50%	100%
5.4 x 10 ⁶	4.6 x 10 ⁶	3.9 x 10 ⁶	2.3 x 10 ⁶	1.4 x 10 ⁶

Example 2

Maximum permitted motor rated current for a contact endurance of 2,000,000 operating cycles at 400V.

Stator contactor	Permitted rated current of slipping motor with inching			
Type	10% approx. A	20% approx. A	50% approx. A	100% approx. A
3TF50 00	75	68	48	33
3TF52 00	110	95	66	48
3TF54 00	175	160	125	80
3TF56 00	240	230	160	120

Draw a line from the point on the left-hand scale indicating the required number of operating cycles to the point on the right hand scale indicating the required number of operating cycles per hour. Then, from the point where this line intersects with the centre axis, draw a horizontal line to the left or right scale for the actual number of daily operating hours.

Note: If a figure of 365 days per annum is being employed instead of 250, the total operating time obtained from the nomogram must be multiplied by 0.68.

Example:

Service requirements: 1.4 million operating cycles endurance, 200 operating cycles per hour, 16 hours service per day.

Result:

Total operating time approx =18 months.

Accessories and ordering data:

AC Coils:

Spare coils for	Type ¹⁾	Std. pkg. (nos.)
3TF50 00 0A..	3TY7 503-0A ..0-0H	1
3TF52 00 0A..	3TY7 523-0A ..0-0H	
3TF54 00 0A..	3TY7 543-0A ..0-0H	
3TF56 00 0A..	3TY7 563-0A ..0-0H	

¹⁾ **Coil voltage code AC 50Hz:**

Coil voltage	110	230	415
Code	F0	P0	R0

(Other coil voltages are also available)

Spares and ordering data

Contact kits:

Spare contact kit for	Type	Std. pkg. (nos.)
3TF50 00 0A..	3TY7 500-0ZA	1
3TF52 00 0A..	3TY7 520-0ZA	
3TF54 00 0A..	3TY7 540-0ZA	
3TF56 00 0A..	3TY7 560-0ZA	

Dimensional drawing

The “Hoisting Duty” Contactors are mechanically similar to our existing 3TF power contactors. Therefore they have exactly same dimensions as the corresponding 3TF power contactors.

Please refer page nos. 21 and 22.

Useful technical information

Starting method of Slip ring motor (AC2 duty):

Three types of the contactors are used to control the three phase slip-ring motors: the stator contactor, the acceleration contactor and the rotor short circuit contactor.

Stator contactor

Initially the stator contactor (K1) is closed to energize the motor. None of the rotor contactor (K2 or K3) is closed yet. Hence all the resistances are present in the rotor circuit. The starting current can reach to 1.5 to 4 times of the rated operational current. The AC2 rating of the stator contactor is selected as per the load factor of the motor.

$$\text{Load factor} = \frac{\text{on time} * 100}{\text{Cycle time (on time + rest time)}}$$

Acceleration contactor

Now acceleration contactor (K2) is closed which short circuits the resistances (R1). The sizing of this contactor (K2) is as per AC1 rated operational current. The current flow time per cycle and the number of cycles per hour has to be considered for the selection.

Rotor short circuit contactor

At the end, the rotor short circuit contactor (K3) closes, short circuiting the last resistance bank (R2) thus remove all the resistances from the rotor circuit. The starting period is hence completed. The duty of this contactors is characterized by the small closing stress. the decisive factor is the thermal stress. The duty factor is considered while finding out the permissible values of the rated operational rotor current for rotor contactors.

Picture below shows the acceleration (K2) and the rotor short circuiting contactor (K3) in the delta connection. If they are connected in star then the ratings are reduced by 35%.

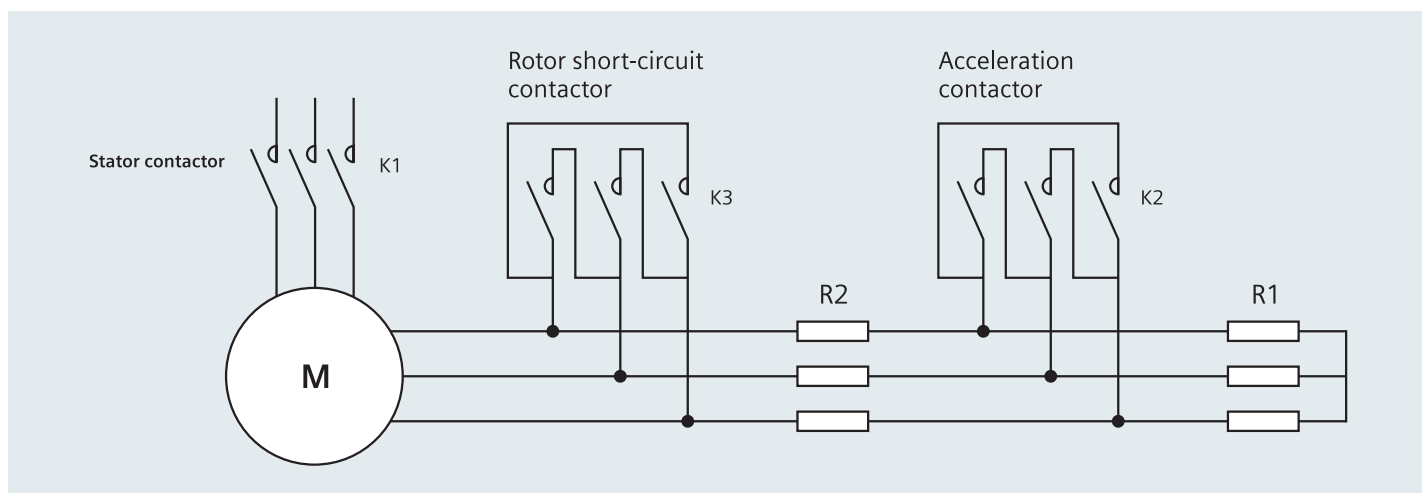

AC1 Duty Contactors 3TK5

When contactors are not required to make or break current but only carry the current, the contactors can be used to its full AC1 rating. Siemens 3TK5 AC1 duty contactors can be offered in such cases.

Application

3TK5 AC1 duty contactors are widely used in sugar mills, DC drives and changeover applications. Also they can be offered for the applications like switching resistive loads, battery charging etc where the AC1 rating of the contactor is suitable.

Standards

3TK5 contactors conform to IS/IEC 60947-4-1. They also carry the CE mark.

Range

3TK5 AC1 duty air break contactors are available from 190A (AC1) to 500A (AC1) in 3 pole version.

Benefits and features

High performance

- **No duration upto 55°C**
SICOP contactors are suitable for operation in service temperature upto 55°C without derating. This avoids selection of higher rated contactor, thereby reducing cost.
- **Long Life**
Superior design of current carrying parts, contact system and the magnet system increases the reliability results into **higher electrical and mechanical endurance**.

High reliability

- High insulation voltage and impulse withstand voltage capacity ensures reliable performance during occasional abnormal increase in supply voltage.

User friendliness and safety

- **Arc Chamber Interlock**
It prevents the contactor from switching ON, if the arc chamber is not fitted properly. Thus avoids accidents to plant and personnel



- **Positively driven contacts**

3TF contactors satisfy the conditions for **positively driven operation** between the main power contacts and the NC contacts. NC contacts positively open before the main contact closes. This is extremely important when power contactors are used in safety circuits of critical applications.

Selection and ordering data

Contactor size	Rated current Ie (A) AC1 at 415V	Type ¹⁾	Std. pkg. (nos.)
6	190	3TK50 02-0A..	1
8	315	3TK52 02-0A..	
10	380	3TK54 02-0A..	
12	500	3TK56 02-0A..	

¹⁾ **Coil voltage code AC 50Hz:**

Coil voltage	110	230	415
Code	F0	P0	R0

Technical data

Contactor	Type	3TK50	3TK52	3TK54	3TK56	
Mechanical Endurance (make/break operations)	Oprns	10 million				
Electrical Endurance in acc. with ACI duty at Ie (make/break operations)	Oprns	0.5 million				
Rated insulation voltage Ui	V	1000				
Permissible ambient temperature	storage	°C -55 to +80				
	service	°C -25 to +55				
Rated impulse withstand voltage Uimp	KV	8				
Rating of contactors for AC loads						
AC-1 duty, switching resistive load						
Rated operational current Ie	40 deg C upto 690V	A	200	340	400	530
	55 deg C upto 690V	A	190	315	380	500
Rating of three-phase loads p.f = 1 at 55 deg C	415V	kW	125	207	250	329
	500V	kW	164	272	329	433
	690V	kW	217	360	434	571
AC-2 and AC-3 duty						
Rated operational current Ie	upto 690V	A	85	105	138	170
Maximum rating of slipring or squirrel cage motors at 50/60Hz	415V	kW	45	55	75	90
	500V	kW	59	72	98	118
	690V	kW	78	96	130	156
Thermal loading	10 s current	A	990	1450	1725	2300
Power loss per current path at Ie/AC3		W	13	19	30	38
Switching frequency z (contactors without overload relay)	No load AC	1/hr	5000	5000	3000	3000
	at AC1	1/hr	650	650	650	650
	at AC3	1/hr	1000	1000	1000	1000
Coil ratings						
AC operation 50Hz	closing	VA	550	910	1430	2450
		p.f	0.45	0.38	0.34	0.21
	closed	VA	39	58	84	115
		P.f	0.24	0.26	0.24	0.33
Coil voltage tolerances			0.8 to 1.1 x Us			
Operating times at 1.0 X Us						
AC operation	closing time	ms	22 to 37	25 to 40	25 to 40	25 to 40
	opening time	ms	8 to 30	10 to 30	10 to 30	8 to 20
Short circuit protection of contactors						
Main circuit	Co-ordination					
	Type 1	A	315	355	500	800
	Type2	A	250	350	500	500



Accessories and ordering data:

Auxiliary contact blocks:

For Contactor	Description	Type	Std. pkg. (nos.)
3TK5	Second 1NO+1NC Left	3TY7 561-1K	1
	Second 1NO+1NC Right	3TY7 561-1L	

Coils:

For Contactor	Type *	Std. pkg. (nos.)
3TK50	3TY7 503-0A..	1
3TK52	3TY7 523-0A..	
3TK54	3TY7 543-0A..	
3TK56	3TY7 563-0A..	

*Please fill in coil codes from table below

Coil voltage code AC 50Hz:

Coil voltage	110	230	415
Code	F0	P0	R0

Spares and ordering data

Contact kits:

Spare contact kit for	Type	Std.pkg. (nos.)
3TK50 02-0A..	3TY7 500-0KA	1
3TK52 02-0A..	3TY7 520-0KA	
3TK54 02-0A..	3TY7 540-0KA	
3TK56 02-0A..	3TY7 560-0KA	

Dimensional drawing

The "3TK5 AC1 duty" Contactors are mechanically similar to our existing 3TF5 power contactors. Therefore they have exactly same dimensions as the corresponding 3TF power contactors. 3TK50, 3TK52, 3TK54 and 3TK56 are having exactly same dimensions as those of 3TF50, 3TF52, 3TF54 and 3TF56 respectively.

Please refer page nos. 21 and 22.





Bimetal Overload Relays 3UA and 3UC

The 3UA / 3UC thermal overload relays are suitable for customers from all industries, who want guaranteed optimum inverse time delayed protection of their electrical loads. The relays meet the requirements of IS/IEC 60947-4-1.

Application

3UA overload relay: 3UA5/6 are 3 pole adjustable bi-metal overload relays mainly suitable for normal starting applications. They provide accurate and reliable protection to motors against overload as per CLASS 10A. They also offer protection against single phasing and unbalanced voltages.

3UC overload relay: 3UC5/6 are 3 pole adjustable, saturable CT operated bi-metal overload relays mainly suitable for heavy starting applications (i.e. when heavy masses are to be put in motion resulting in larger starting period). They provide accurate and reliable protection to motors against overload as per CLASS 30. They also offer protection against single phasing and unbalanced voltages.

If single-phase AC or DC loads are to be protected by the 3UA / 3UC thermal overload relays, all three bimetal strips must be heated. For this purpose, all main current paths of the relay must be connected in series.

Standards

Bimetal relays conform to IS/IEC 60947-4-1. They also carry the CE mark.

Range

3UA5: 0.1 to 120A, (Class 10A, without CT)

3UA6: 85 to 630A, (Class 10A, CT operated)

3UC5/6: 2.4 to 400A (Class 30, CT operated)

Relay overview

Overload relay operates on the bi-metallic principle. The heater winding wound on the bimetal strips carry the current flowing through the motor. In case of overload, the current carried through the heater winding is more than the rated current. This heats up the bimetal strips. Due to this bi-metal strips bend and open the NC contact of the relay, which is connected in the control circuit of the contactor, thus disconnects the motor from the supply. The tripping time is inversely proportional to the current flowing through the bi-metal strips. Bi-relays are therefore, referred to as "current dependent" and inverse-time delayed relays.

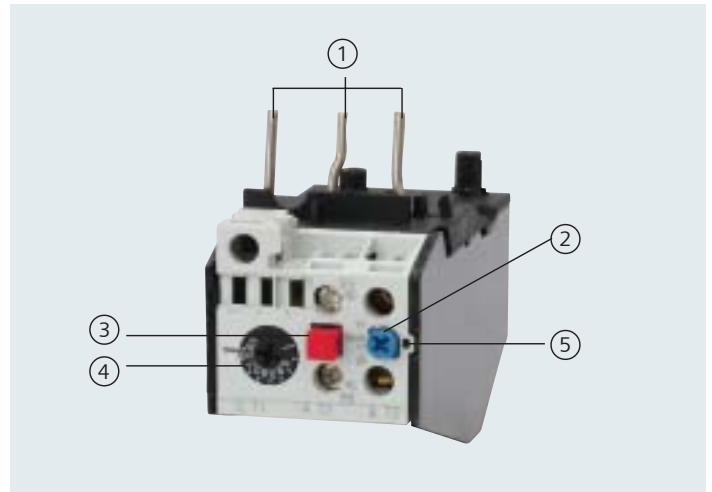

1. Connection for mounting onto contactors:

Optimally adapted in electrical, mechanical and design terms to the contactors, these connecting pins can be used for direct mounting of the overload relays. Stand-alone installation is possible as an alternative (in some cases in conjunction with a stand-alone installation module).

2. Selector switch for manual/automatic RESET (blue):

With this switch you can choose between manual and automatic RESET. A device set to manual RESET can be reset locally by pressing the RESET button. A remote RESET is possible using the RESET modules (accessories), which are independent of size.

3. TEST button (red):

Trip circuit can be manually checked by using this button. During this simulation the NC contact (95-96) is opened and the NO contact (97-98) is closed. This tests whether the auxiliary circuit has been correctly connected to the overload relay. The relay must be reset with the RESET button if it has been set to manual RESET. If the thermal overload relay has been set to automatic RESET, then the overload relay is automatically reset when the TEST button is released.

4. Motor current setting dial:

Setting the device to the rated motor current is easy with the large rotary knob. (Recessed dial, hence no possibility of accidentally change in current setting.)

5. Trip indicator (Green):

A separate mechanical Green Trip Indicator is provided on the front cover of the relay to indicate the tripped state of the 'manual reset' relay.

Recovery time

After tripping due to overload, the thermal overload relays require some time until the bimetal strips have cooled down. The device can only be reset after the bimetal strips have cooled down. This time (recovery time) depends on the tripping characteristics and strength of the tripping current. The recovery time allows the load to cool down after tripping due to overload.

Benefits and features

High performance

- **In-built single phasing protection**

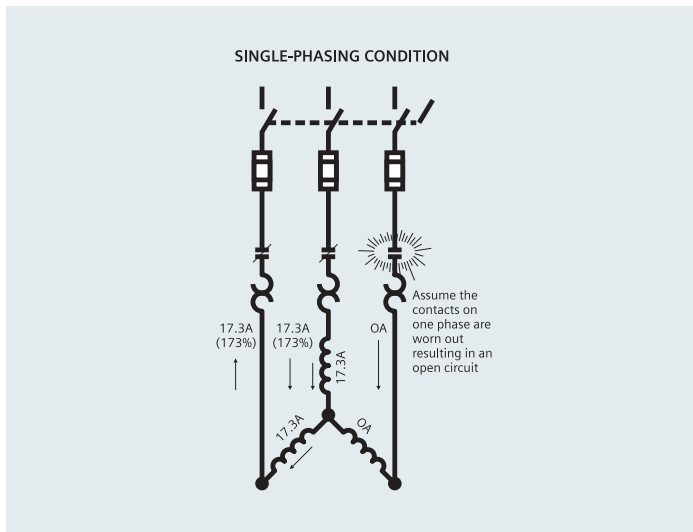

In case of phase loss the current through the other two windings increases by 1.732 times the rated current of the motor. The current now flows only through the 2 bimetallic strips which should produce the required force on the tripping mechanism. This needs higher currents for longer time. As current is not too high so the relay might take higher time to trip. This can cause damage to the motor. Similar condition happens in case of phase unbalance. To take care of these conditions our birelays are constructed such that they offer a built-in single phasing protection using differential slider principle.

- **Temperature compensation**

The temperature compensation feature reduces the effect of the ambient temperature on the tripping behavior. This ensures the minimum tripping current lies within the specified range

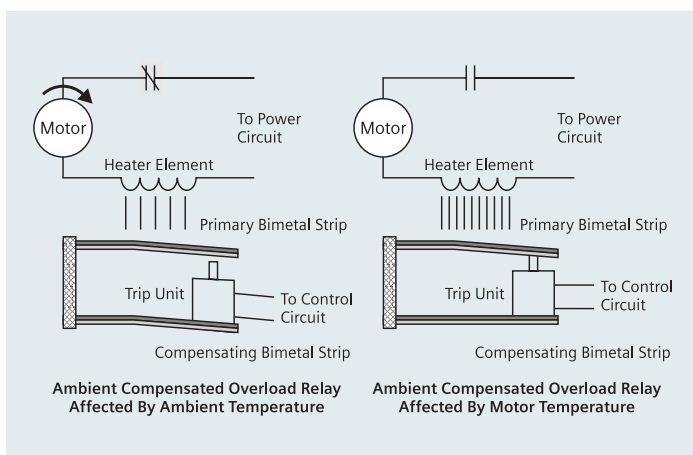

for -25 to 55° C. For this purpose the relays are temperature compensated between service temperatures of -25° C to +55° C.

User friendliness and safety

- **SIGUT termination Technique**

- **Shrouded auxiliary terminals**

Increases safety, as they protect against accidental contact with live parts.

- **Funnel shaped cable entries**

Reduce wiring time by facilitating quick location of the connecting wire.

- **Cable end-stop**

They decide the insertion depth of the connective wire. As the wire cannot now protrude into the relay housing, it does not hamper the movement of the auxiliary contacts. Since the insertion depth is predetermined, insulation of the cable can be cut accordingly and the possibility of insulation getting inadvertently caught under the terminal, is avoided.

- **Captive Screws**

This feature prevents the screws from falling down thereby facilitates the wiring. Hence, the relays are delivered with untightened terminals. This eliminates the operation of untightening terminals before wiring.

- **Lug less termination**

This feature helps in reducing the termination time.

- **Screw-driver guides** reduce wiring time as they allow the use of power screw-drivers.

Flexibility

- **Potential free Auxiliary Contacts**

Potential free 1NO + 1NC contact arrangement is provided as a standard feature. The 1NC contact is used in the control circuit of the contactor for disconnecting the motor in case of overload, whereas the 1NO contact can be used for various applications such as indication.

- **Mounting**

3UA5: suitable for direct mounting or independent mounting (with the help of independent mounting accessory)

3UA6 and 3UC5/6: suitable for Independent mounting.

Selection and ordering data:

Setting range (A)	Type reference	Backup HRC fuse 3NA A (max)	Mounting	Std. pkg. (nos.)		
Normal Motor Starting time						
3UA50						
0.1 - 0.16	3UA50 00-0A	2	With Contactor 3TF30/31	1		
0.16 - 0.25	3UA50 00-0C	2				
0.25 - 0.4	3UA50 00-0E	2				
0.4 - 0.63	3UA50 00-0G	2				
0.63 - 1	3UA50 00-0J	2				
0.8 - 1.25	3UA50 00-0K	4				
1 - 1.60	3UA50 00-1A	6				
1.25 - 2	3UA50 00-1B	6				
1.6 - 2.5	3UA50 00-1C	6				
2 - 3.2	3UA50 00-1D	10				
2.5 - 4	3UA50 00-1E	10	With Contactor 3TF32/33	1		
3.2 - 5	3UA50 00-1F	16				
4 - 6.3	3UA50 00-1G	16				
5 - 8	3UA50 00-1H	20				
6.3 - 10	3UA50 00-1J	25				
8 - 12.5	3UA50 00-1K	25				
10 - 14.5	3UA50 00-2S	25				
1 - 1.6	3UA52 00-1A	6			With Contactor 3TF32/33	1
1.25 - 2	3UA52 00-1B	6				
1.6 - 2.5	3UA52 00-1C	6				
2 - 3.2	3UA52 00-1D	10				
2.5 - 4	3UA52 00-1E	10				
3.2 - 5	3UA52 00-1F	16				
4 - 6.3	3UA52 00-1G	16				
5 - 8	3UA52 00-1H	20				
6.3 - 10	3UA52 00-1J	25				
8 - 12.5	3UA52 00-1K	25				
10 - 16	3UA52 00-2A	32	With Contactor 3TF34/35	1		
12.5 - 20	3UA52 00-2B	50				
16 - 25	3UA52 00-2C	50				
20 - 32	3UA55 00-2D	80				
25 - 36	3UA55 00-2Q	80				
32 - 40	3UA55 00-2R	80				
36 - 45	3UA55 00-8M	80				
3UA58						
16 - 25	3UA58 00-2CZ1	50			With Contactor 3TF46 3TF47 3TF48 3TF49	1
20 - 32	3UA58 00-2DZ1	63				
25 - 40	3UA58 00-2EZ1	80				
32 - 50	3UA58 00-2FZ1	100				
40 - 57	3UA58 00-2TZ1	100				
50 - 63	3UA58 00-2PZ1	125				
57 - 70	3UA58 00-2VZ1	125				
63 - 80	3UA58 00-2UZ1	160				
70 - 95	3UA58 00-8YZ1	160				
16 - 25	3UA58 00-2CZ2	50	With Contactor 3TF47 7	1		
20 - 32	3UA58 00-2DZ2	63				
25 - 40	3UA58 00-2EZ2	80				
32 - 50	3UA58 00-2FZ2	100				
40 - 57	3UA58 00-2TZ2	100				
50 - 63	3UA58 00-2PZ2	125				
57 - 70	3UA58 00-2VZ2	125				
63 - 80	3UA58 00-2UZ2	160				

Setting range (A)	Type reference	Backup HRC fuse 3NA A (max)	Mounting	Std. pkg. (nos.)
3UA58 30				
70 - 95	3UA58 30-5B	160	With Contactor 3TF50	1
85 - 105	3UA58 30-5C	160		
95 - 120	3UA58 30-5D	200		
3UA62 30				
85 - 135	3UA62 30-5A	224	Independent	1
115 - 180	3UA62 30-5B	250		
160 - 250	3UA62 30-5C	400		
200 - 320	3UA62 30-5D	400		
250 - 400	3UA62 30-5E	500		
3UA68 30				
320 - 500	3UA68 30-5F	500	Independent	1
400 - 630	3UA68 30-5G	630		
Long Motor Starting time (Heavy duty)				
3UC50 30				
2.5 - 4	3UC50 30-5E	16	Independent	1
4 - 6.3	3UC50 30-5G	25		
6.3 - 10	3UC50 30-5J	25		
8 - 12.5	3UC50 30-5K	32		
3UC58 30				
10 - 16	3UC58 30-5A	32	Independent	1
16 - 25	3UC58 30-5C	63		
25 - 40	3UC58 30-5E	100		
40 - 63	3UC58 30-5G	125		
3UC62 30				
63 - 100	3UC62 30-5J	250	Independent	1
100 - 160	3UC62 30-5A	315		
3UC66 30				
125 - 200	3UC66 30-5B	500	Independent	1
160 - 250	3UC66 30-5C	630		
250 - 400	3UC66 30-5E	630		

Technical Data

Type		3UA50	3UA52	3UA55	3UA58	3UA5830	3UA6230	3UA6830	3UC5030	3UC5830	3UC6230	3UC6630
Trip class		10A							30			
Phase failure protection		✓	✓	✓	✓	✓	✓	✓	✓	✓	✓	✓
Changeover to auto-reset at site		✓	✓	✓	✓	✓	✓	✓	✓	✓	✓	✓
RESET button (trip-free) Blue		✓	✓	✓	✓	✓	✓	✓	✓	✓	✓	✓
Ambient temperature compensation		✓	✓	✓	✓	✓	✓	✓	✓	✓	✓	✓
Trip indicator Green		✓	✓	✓	✓	✓	✓	✓	✓	✓	✓	✓
TEST button Red		✓	✓	✓	✓	✓	✓	✓	✓	✓	✓	✓
Terminal for contactor coil		✓	✓	✓	X	X	X	X	X	X	X	X
Permissible service temperature		25°C to +55°C										
Mounting		Contactor/ 3TF30/31	Contactor/ 3TF32/33	Contactor/ 3TF34/35	Contactor/ 3TF46 to 49	Contactor/ 3TF50	Independent					
Main Circuit												
Rated current (Max)	A	14.5	25	45	95	120	400	630	12.5	63	160	400
Rated insulation voltage U_i (Pollution degree 3)	V	690	690	690	1000	1000	1000	1000	1000	1000	1000	1000
Rated impulse withstand U_{imp}	kV	6	6	6	8	8	8	8	8	8	8	8
Heating		Direct	Direct	Direct	Direct	Direct	Indirect	Indirect	Indirect	Indirect	Indirect	Indirect
Conductor cross-section												
Solid or stranded	sqmm	2.5 to 6	2.5 to 6	1.5 to 25	2.5 to 35	35 to 70	50 to 120/ 240*	2 x 240	1 to 4	–	–	–
Finely stranded with end sleeve	sqmm	1.5 to 4	1.5 to 4	1 to 16	1.5 to 25	–	–	–	1 to 2.5	35	120	240
Multi-conductors with cable lugs	sqmm	–	–	–	–	–	50 to 120/ 240*	2 x 240	–	–	–	–
Flats	sqmm	–	–	–	–	–	1 x 20 x 3	2 x 30 x 5	–	1 x 15 x 3	1 x 20 x 5	2 x 30 x 5 2 x 3- x 5*
Terminal screw		M4	M4	M5	M5	M8	M10	M10	M4	M6	M8	M10
Power loss per pole (max)												
Minimum setting	W(VA)	0.9	0.9	1.2	2.6	2.8	5	6(9)	2.5	2.5	3.5	5.5
Maximum setting	W(VA)	2.25	2.25	3	4	4	7	15(22)	6.5	6.5	9	14
Auxiliary Circuit (application for all types)												
Auxiliary contacts		1NO + 1NC (Potential free)										
Rated thermal current I_{th}	A	6										
Short circuit protection (max)	A	6 (HRC Fuse type 3NA7)										
Switching capacity	AC15	V	24	60	125	230	415	500				
		A	2	1.5	1.25	1.15	1	1				
	DC13	V	24	60	110	220						
		A	1	0.4	0.22	0.1						
Conductor cross-section												
Solid or stranded	sqmm	2 x (1 to 2.5)										
Finely started with end sleeve	sqmm	2 x (0.75 to 1.5)										
Terminal screw		M3.5										

* For relay above 180 A

Characteristic Curves

Tripping characteristics

The current/time curves show the relationship between the tripping time from cold state and multiples of the set current I_e . When the relay is at operating temperature and carrying 100 % I_e , the tripping times are reduced to approximately 25 %. Tripping curve is applicable to 3-pole loads and 2-pole loads. For single-pole loads, the tripping curves lie between curves of 3-pole loads and 2-pole loads.

For normal operation, all 3 bimetallic strips of the overload relay must be heated. The overload relays 3UA / C are suitable for protecting motors with phase control. For protecting single-phase or DC-loads, therefore, all three main conducting paths must be connected in series. Tripping curve for 3 pole loads is then applicable. The release current with a 3-pole symmetrical load is between 105 % and 120 % of the set current.

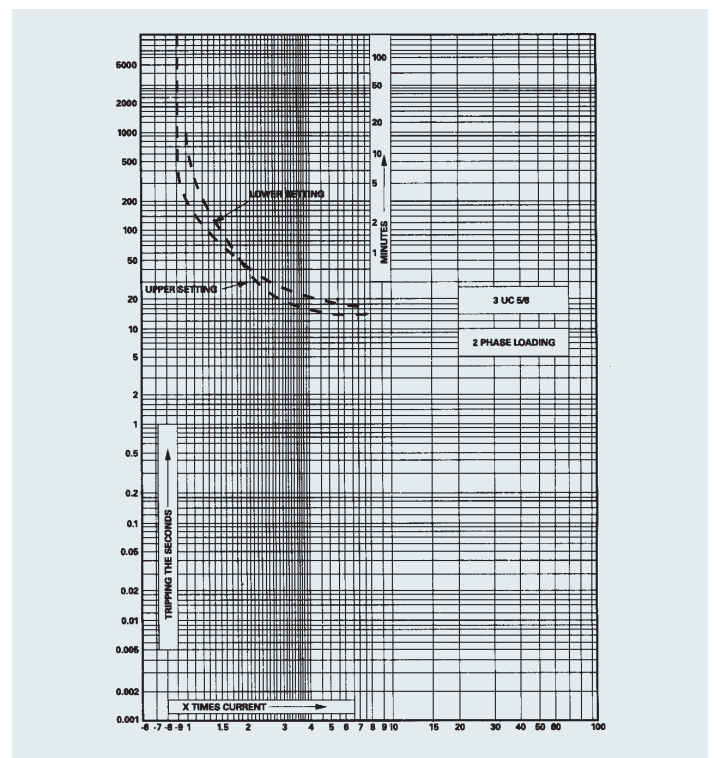
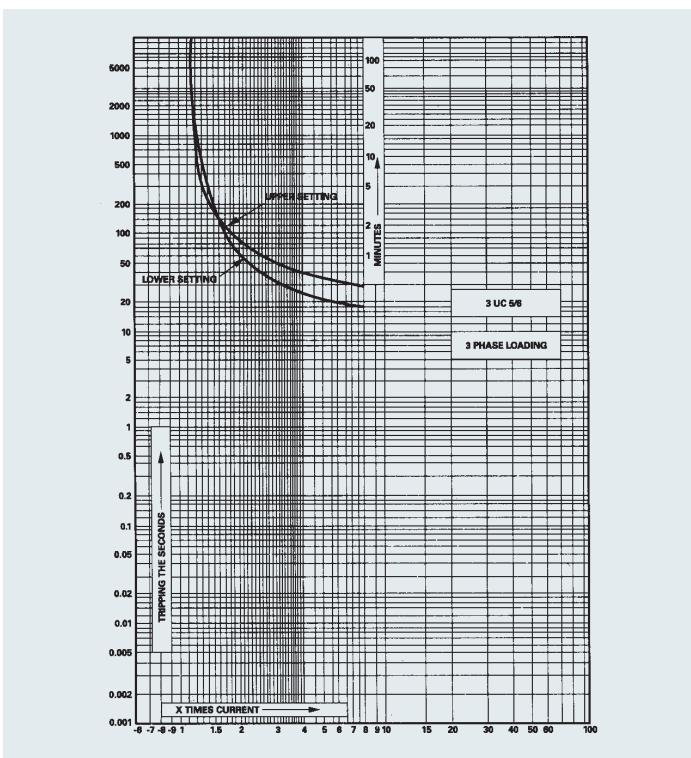
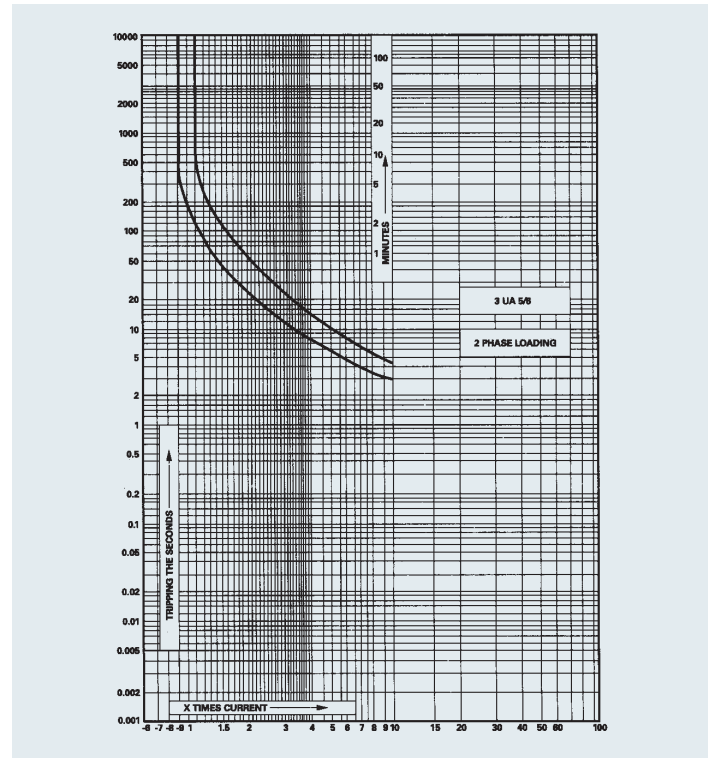
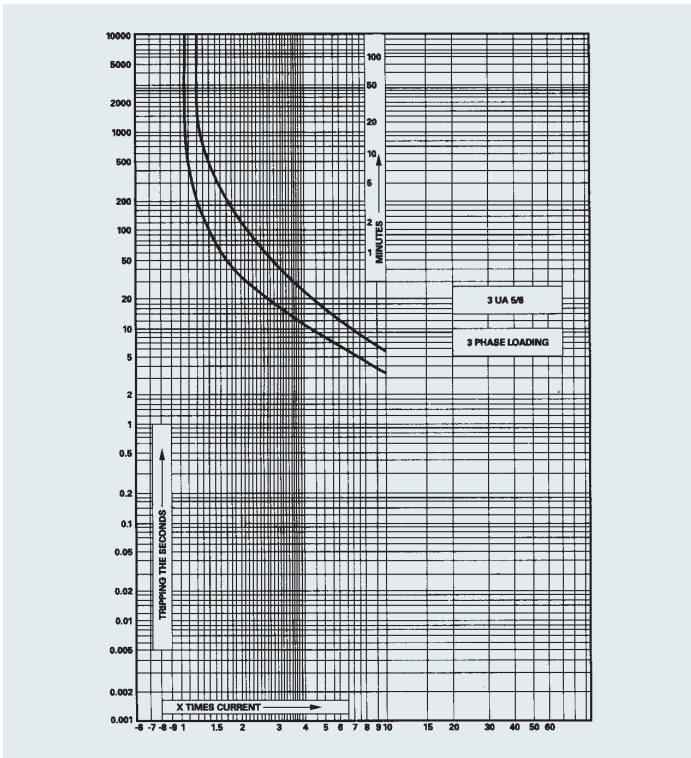

The above curves are the general characteristics curves; for individual characteristics curves of each rating, please contact our nearest sales office.

Accessories and ordering data

1. **Adaptor:** To convert contactor mounting relay to independent mounting, (Fig. 1) suitable for screw type mounting and 35 mm DIN rail mounting.
2. **Protective cover*:** To avoid tampering of the setting, auto manual mode or test button. (Fig. 2)
3. **Reset cord*:** To reset the relay in switchboard with door closed. (Length: 600 mm) (Fig. 3)
4. **Reset plunger with funnel*:** Instead of reset cord for resetting the relay in switchboard with door closed. (Fig. 4)

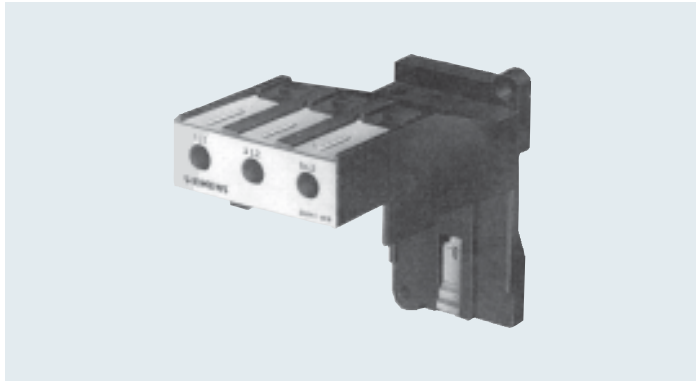

Fig. 1: Adaptor

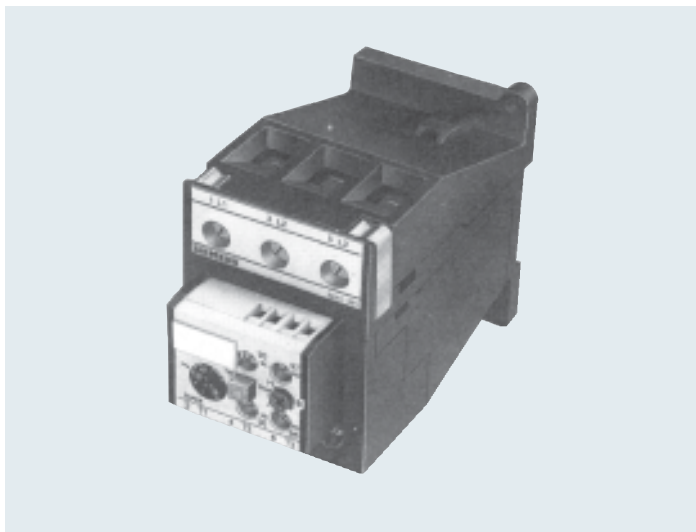

Fig. 1: Relay with adaptor for independent mounting

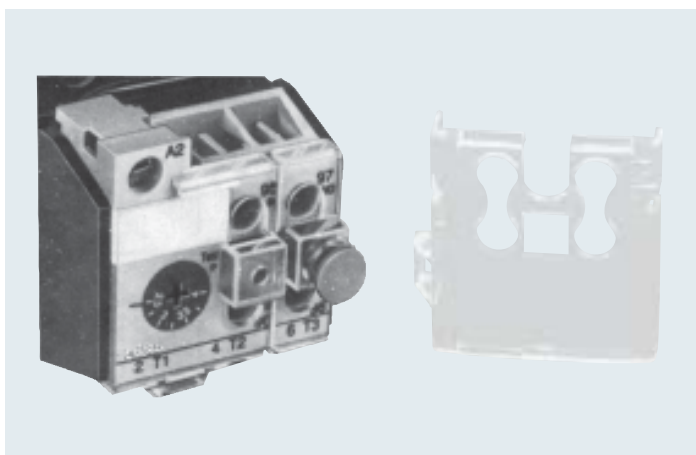

Fig. 2: Protective cover



Fig. 3: Reset cord with holder

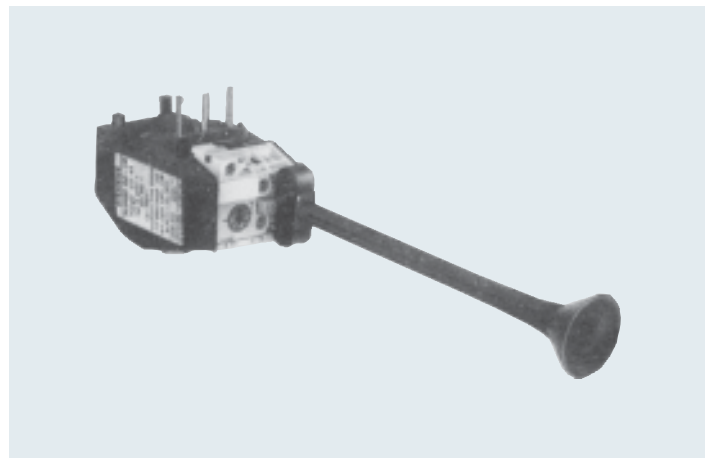

Fig. 4: Reset plunger + Funnel

Description	Type reference	Relay type	Std. pkg. (nos.)
Reset Plunger	3UX1 011	3UA5/6, 3UC5/6	10
Funnel	3UX1 013		
Reset cord with Holder (600mm)	3UX1 016	3UA5/6, 3UC5/6	5
Protection Cover	3UX1 111 - 1YA 3UX1 110 - 1YA	3UA5/6 3UA58/5830	10
Adaptor to convert to independent mounting	3UX1 418 3UX1 420 3UX1 425 3UX1 421 3UX1 421 - 0XA	3UA50 3UA52 3UA55 3UA58 3UA5830	1
Set of terminals to convert relay type	3UX58 11	3UA5800-2 or to 3UA5800-2 Z2 to 3UA5800-2 Z1	10
	3UX58 12	3UA5800-2 Z1 or 3UA5800-2 Z2 to 3UA5800-2	
	3UX58 13	3UA5800-2 or 3UA5800-2 Z1 to 3UA5800-2 Z2	

* Only one accessory at the time

Dimensional Drawing

3UA50 with independent Mounting Adapter Type 3UX1 418

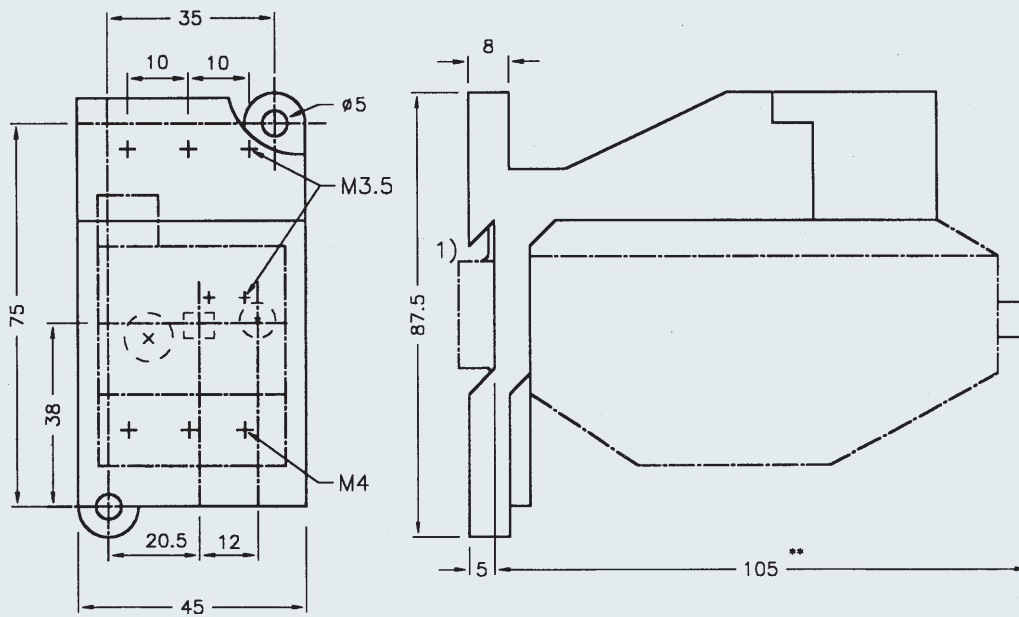

- ** Dimension for the square OFF-button (stroke 3mm)
 Dimension for the round RESET-button (stroke 2.5mm) less 2.5mm
- 1) For 35mm standard (DIN) mounting rail

3UA50 mounted on 3TF30/31

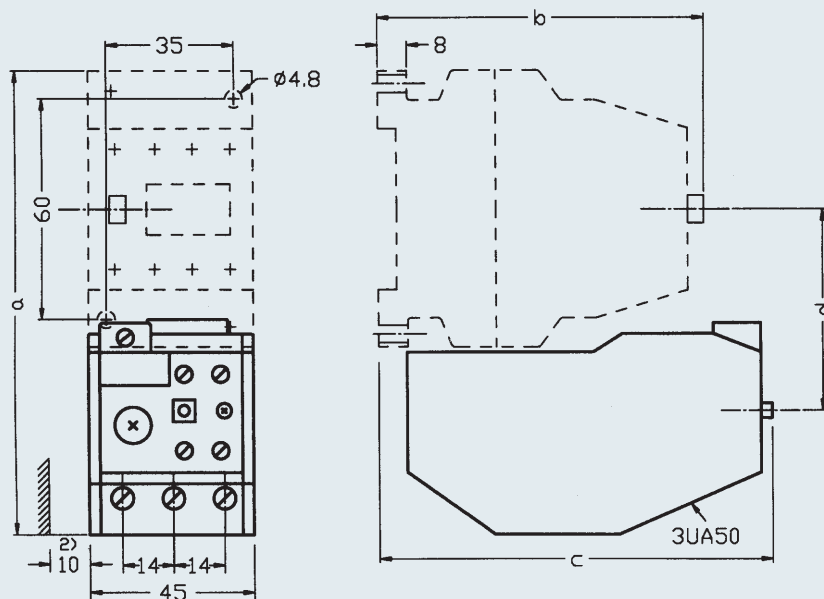

Auxiliary Contact	a	b	c	d
1NO or 1NC	125	85	108	55
1NO + 1NC or 2NO + 2NC	130	100	100	60

2) Minimum clearance from earthed element 10mm

3UA52/55 with independent mounting

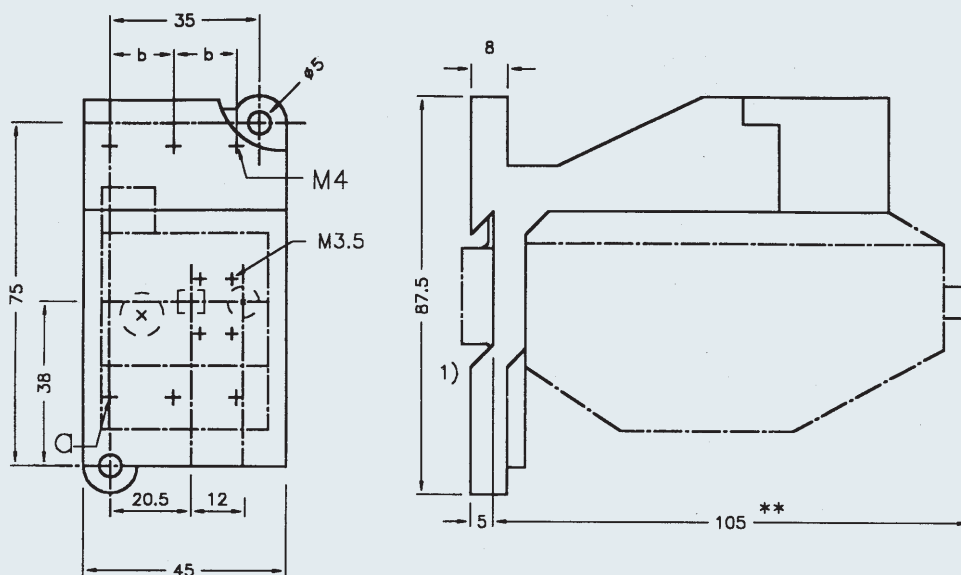

- ** Dimension – For square OFF button (Stroke 3mm)
 – For Round RESET button (Stroke 2.5mm) less 2.5 mm
- 1) Suitable for DIN RAIL 35mm as per DIN EN 50022

Type	Dim	
	a	b
3UA52 + 3UX1420	M4	14.3
3UA55 + 3UX1425	M5	18.2

3UA52 mounted on 3TF 32/33

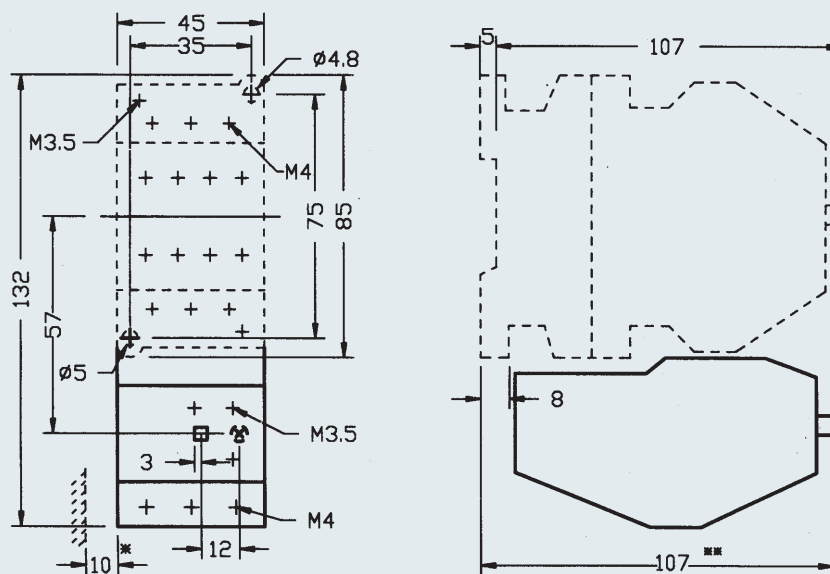

- * Minimum clearance from the earthed components
- ** Dimension – For square OFF button (Stroke 3mm)
 – For Round RESET button (Stroke 2.5mm) less 2.5mm

3UA55 mounted on 3TF 34/35

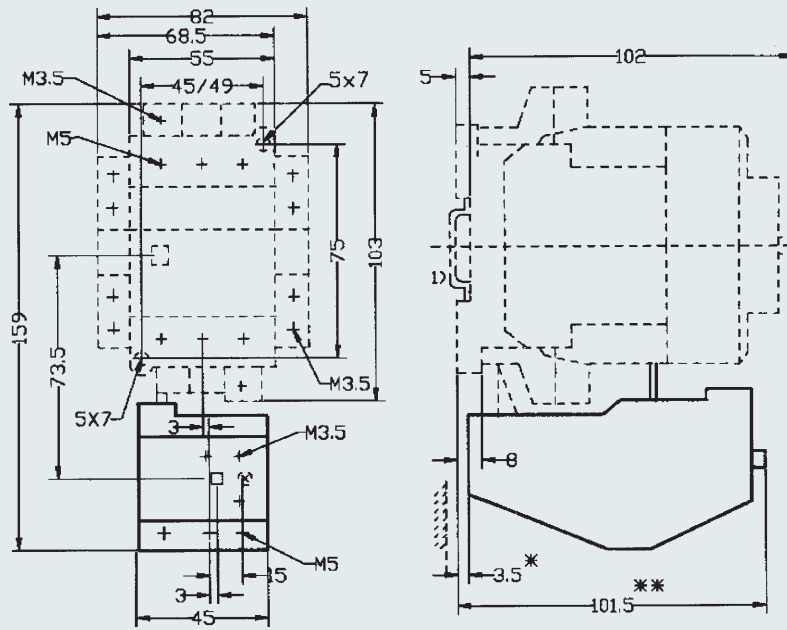

- * Minimum clearance from the earthed components
- ** Dimension – For square OFF button (Stroke 3mm)
– For round RESET button (Stroke 2.5mm) less 2.5mm
- 1) Suitable for DIN RAIL 35mm as per DIN 50022

3UA58 with independent mounting adaptor type 3UX1 421

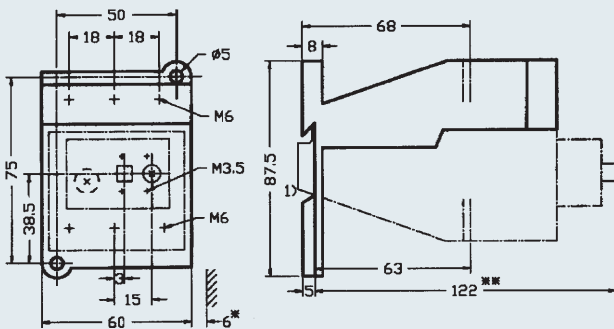

- * Minimum clearance from the earthed components
- ** Dimension – For square OFF button (Stroke 3mm)
– For round RESET button (Stroke 2.5mm) less 2.5mm
- 1) Suitable for DIN RAIL 35mm as per DIN 50022

3UA5800 mounted on 3TF46/47
3UA5800_.. Z1 mounted on 3TF48/49

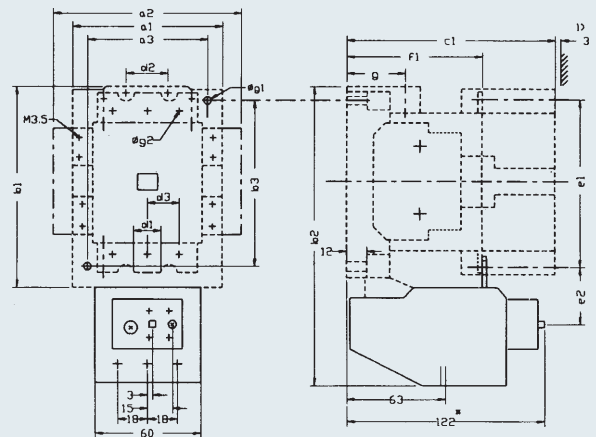

- * Dimension – For square OFF button (Stroke 3mm)
– For round RESET button (Stroke = 2.5mm) less 2.5mm
- 1) Minimum clearance from insulated components : 3mm
Minimum clearance from earthed components: 10mm

3UA58+	a1	a2	a3	b1	b2	b3	c1	d1	d2	d3	e1	e2	f1	f2	f3	g	φg1	φg2
3TF46/47	90	113	70	117	175	100	123	8	25	25	94	34	80	63	122	28	4.8	6.1
3TF48/49	100	123	80	133	194	110	140	10.5	25	26.5	116	31.5	89	71	132	39	5.5	6.1

3UA5800_.. Z2 mounted on 3TF47 7

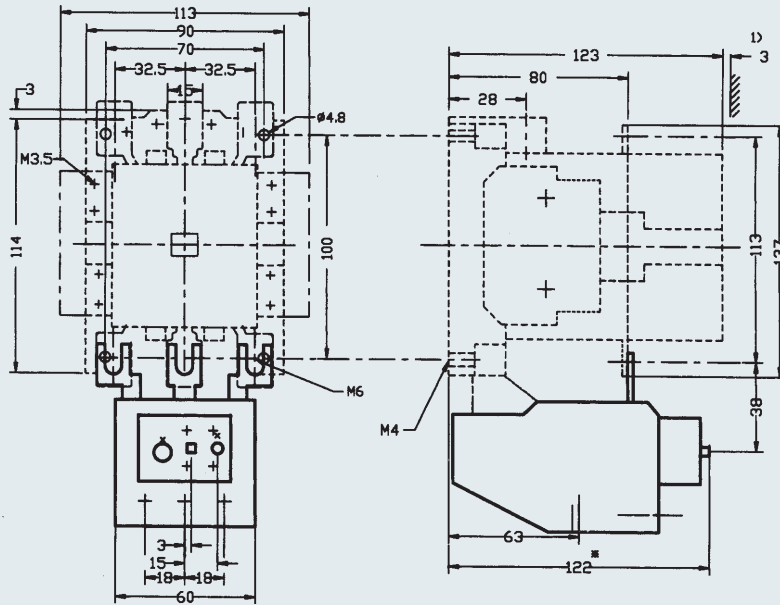

* Dimension – For square OFF button (Stroke 3mm)
 – For round RESET button (Stroke = 2.5mm) less 2.5mm

- 1) Minimum clearance from insulated components : 3mm
 Minimum clearance from earthed components: 10mm

3UA5830 with individual mounting adaptor type 3UX1 421 - OXA

3UA5830 mounting on 3TF50

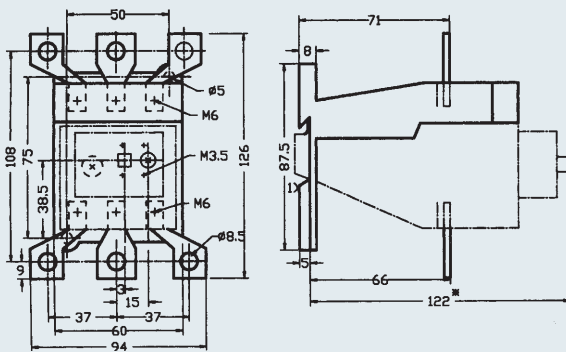

* Dimension – For square OFF button (Stroke 3mm)
 – For round RESET button (Stroke 2.5mm) less 2.5mm

- 1) Suitable for DIN RAIL 35mm as per DIN 50022

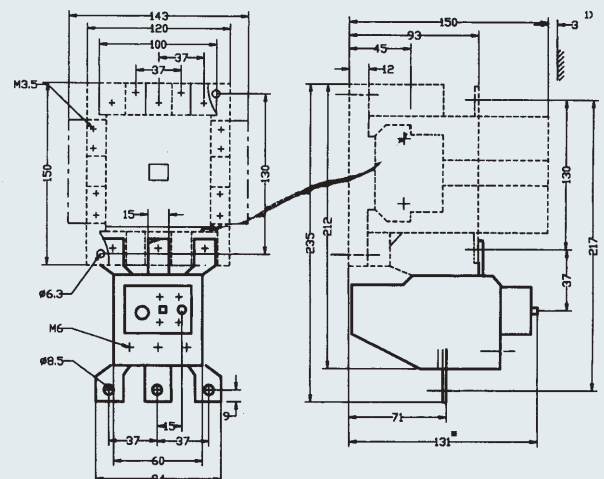

* Dimension – For square OFF button (Stroke 3mm)
 – For round RESET button (Stroke 2.5mm) less 2.5mm

- 1) Minimum clearance from insulated components : 3mm
 Minimum clearance from earthed components: 10mm

3UA6230 CT Operated Birelay

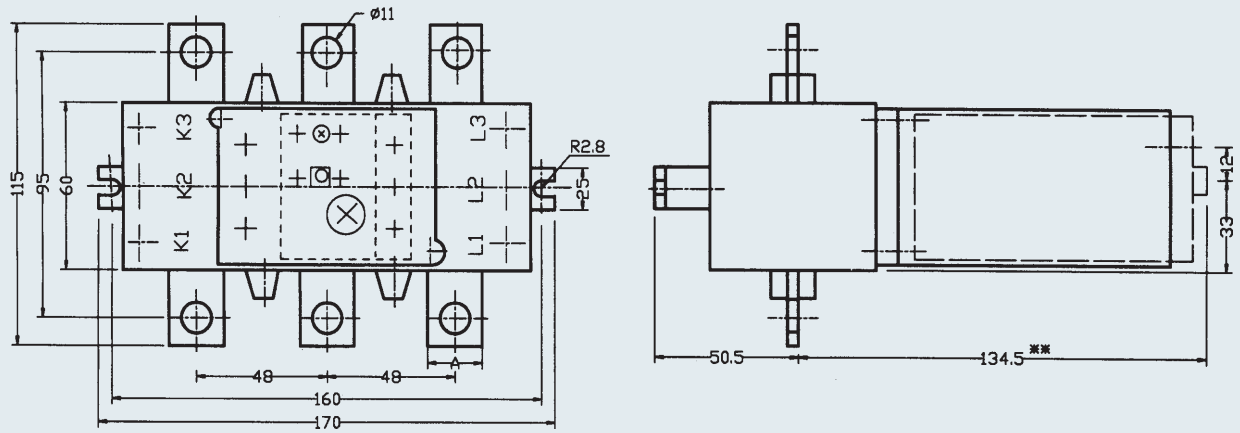

** Dimension – For square OFF button (Stroke 3mm)
 – For round RESET button (Stroke 2.5mm) less 2.5mm

3UA68 CT Operated Birelay

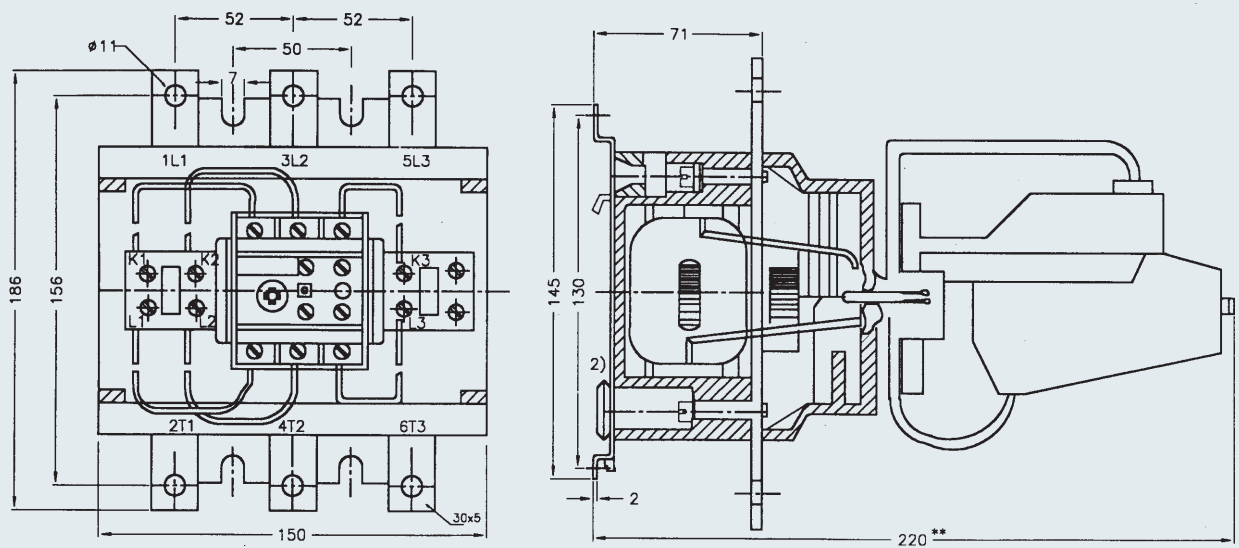

** Dimension – For TEST button (Stroke 3mm)
 – For Round RESET button (Stroke 2.5mm) less 2.5mm

2) Suitable for DIN RAIL 75mm as per DIN EN 50023

3UC50 CT Operated Birelay

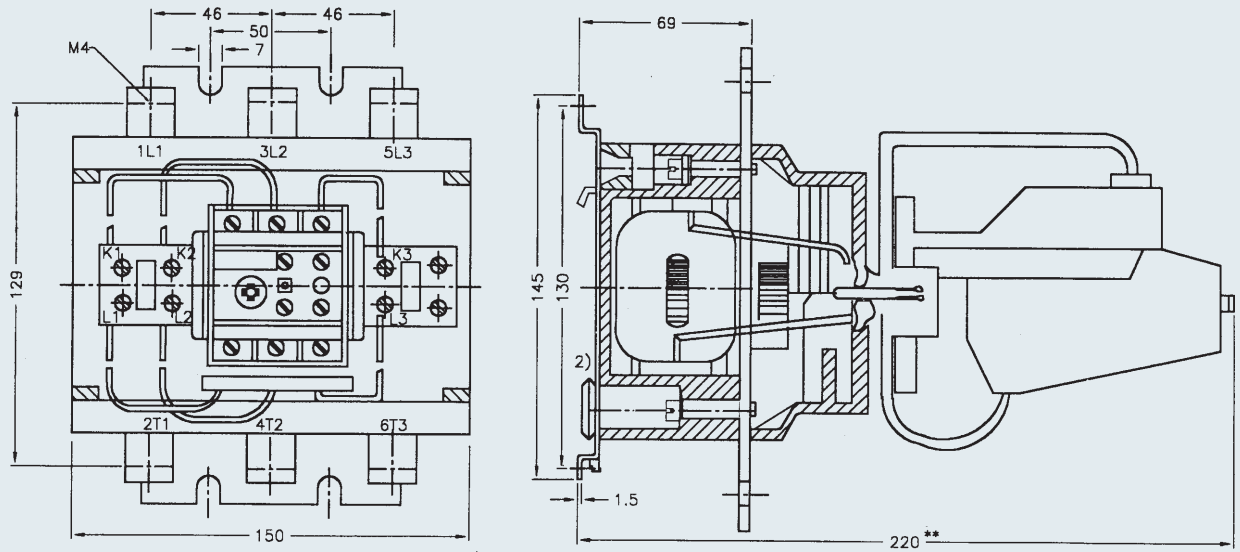

- ** Dimension – For Square OFF button (Stroke 3mm)
 – For Round RESET button (Stroke 2.5mm) less 2.5mm
 2) Suitable for DIN RAIL 75mm as per DIN EN 50023

3UC5830/3UC6230/3UC6630 CT Operated Birelay

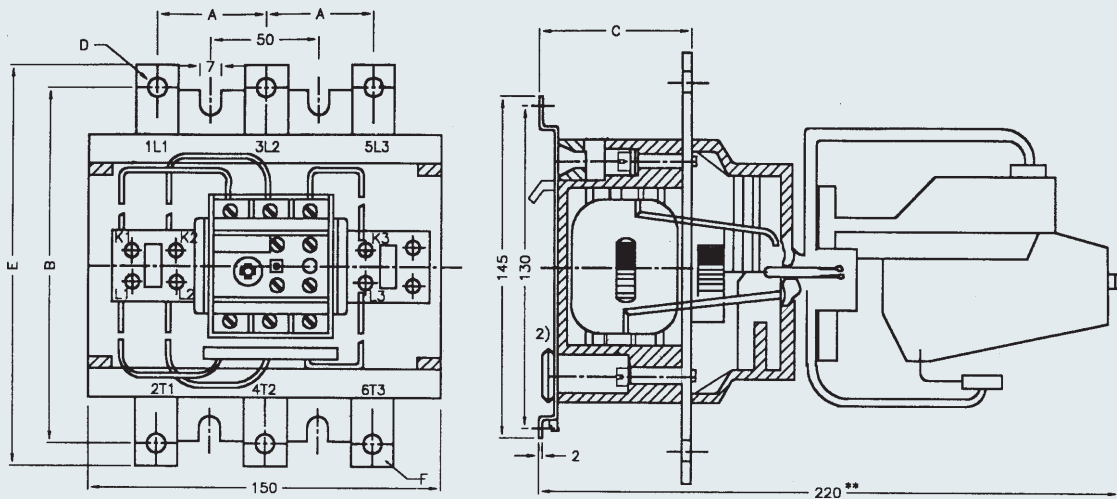

Relay Type	A	B	C	D	E	F
3UC58 30	46	135	69	6.6	150	15x3
3UC62 30	46	140	69	9	160	20x3
3UC66 30-5B (200A)	50	146	69	9	160	20x3
3UC66 30-5C-5E(400A)	50	146	70	11	171	25x4

- ** Dimension – For TEST button (Stroke 3mm)
 – For Round RESET button (Stroke 2.5mm) less 2.5mm
 2) Suitable for DIN RAIL 75mm as per DIN EN 50023

Motor Protection Circuit Breakers

3VU13 and 3VU16

3VU13/3VU16 is suitable for use in fuseless motor feeders upto 11KW/22KW (25A/63A) respectively. 3VU motor protection circuit breakers are used for protection of motor against overload, single phasing and short-circuit faults.

Applications

- **Motor Protection**

Circuit breakers type 3VU13 & 3VU16 offer overload, short circuit and phase loss protection for 3 phase motors upto 11kW and 22 kW respectively. The breaker has a toggle switch for ease of operation and can be offered with auxiliary contacts, trip indicating contacts, U/V or Shunt release. High breaking capacity of 100kA is available in 3VU13 upto 6A and in 3VU16 upto 25A.

- **Distribution Feeder Protection**

Standard version of 3VU13 and 3VU16 has adjustable O/L and fixed S/C release. Main application is for disconnection and protection of the distribution feeders, upto 25A and 63A respectively. A large number of overlapping ranges are available for offering closer protection to various loads.

- **Transformer protection**

A separate 3VU13 range can be offered to protect the primary side of the transformers. The range is available upto 20A. To take care of the inrush current due to transformer switching, the S/C release is set at 19 times the rated current unlike 12 times of the rated current available in standard range.

- **Fuse Monitoring**

3VU1340-1MS00 is offered for Fuse Monitoring application. This device is connected in parallel to the fuses. In case one of the fuses blows, the rated current will flow through the corresponding phase of this MPCB. MPCB, through its auxiliary contacts, provides a tripping signal to the contactor and thus the motor will be switched off. Hence, the motor will be protected from single phasing. (Refer page 51 for connection diagram)



3VU13/16

Standard

3VU motor protection circuit breakers conform to IS/IEC 60947-1, IS/IEC 60947-2, IS/IEC 60947-4-1, DIN VDE 0660

Range

3VU13: 0.16 - 25A

3VU16: 10 - 63A

Benefits and features

High performance

- **Instantaneous Tripping**

3VU circuit breakers operate on the **Current Limiting Principle**.

Current Limiting Principle

In case of short-circuit condition motor protection circuit breaker trips before the short-circuit current reaches the prospective peak. Hence, for circuit breaker to be current limiting it must interrupt the short-circuit current in half cycle or less as shown below.

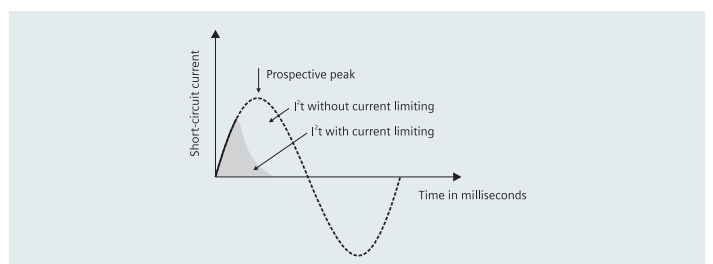

Fuse Monitoring MPCB - 3VU1340-1MS00

Current Limiting is achieved in 3VU as follows

In case of a short circuit, the contacts are opened electro-dynamically by the short circuit current. The instantaneous overcurrent release, through the switching mechanism, trips all the three poles of the breaker. A large arc voltage is quickly built up in the arc chamber limiting the short circuit current. Thus ensures faster fault clearing.

- Ambient temperature compensation upto 55°C hence no deration required upto 55°C.

Safety

• Trip Free Mechanism

The breakers have a trip-free mechanism. Even by holding the toggle, tripping operation can not be stopped or blocked once it is started. Thus ensure positive opening in the event of fault.

- Positive ON/OFF indication through toggle switch
- Compact and space saving

User friendliness and safety

- SIGUT® connection technique ensures ease of wiring (can obviate use of lug)
- Fingers touch proof terminals ensures operator safety
- Separate trip indication on short circuit and overload fault using alarm contact

Flexibility

- Can be used as a main and EMERGENCY STOP switch.
- Identical accessories reduce stock levels

Selection and ordering data

3VU13 Circuit - breakers with 1NO+1NC auxiliary contacts for motor and plant protection

Rated Current In A	Overload release range A	Shortcircuit release setting A	Type ⁵	Recommended 415V Motor Rating in Kw/HP (DOL)	Std. pkg. (nos.)
0.16	0.1 - 0.16	1.9	3VU1340-1MB00	–	1
0.24	0.16 - 0.24	2.9	3VU1340-1MC00	–	
0.4	0.24-0.4	4.8	3VU1340-1MD00	–	
0.6	0.4-0.6	7.2	3VU1340-1ME00	–	
1	0.6-1	12	3VU1340-1MF00	0.25/0.33	
1.6	1-1.6	19	3VU1340-1MG00	0.37/0.5	
2.4	1.6-2.4	29	3VU1340-1MH00	0.75/1	
3.2	2-3.2	38	3VU1340-1NH00	1.1/1.5	
4	2.4-4	48	3VU1340-1MJ00	1.5/2	
5	3.2-5	60	3VU1340-1NJ00	2.2/3	
6	4-6	72	3VU1340-1MK00	3/4	
8	5-8	96	3VU1340-1NK00	3.7/5	
10	6-10	120	3VU1340-1ML00	4/5.4	
13	8-13	156	3VU1340-1NL00	5.5/7.5	
16	10-16	190	3VU1340-1MM00	7.5/10	
20	14-20	240	3VU1340-1MN00	9.3/12.5	
25	18-25	300	3VU1340-1MP00	11/15	

3VU13 Circuit - breakers with 1NO+1NC auxiliary contacts for line-side protection of transformers with high inrush current

Rated Current In A	Overload release range A	Shortcircuit release setting A	Type	Std. pkg. (nos.)
0.6	0.4-0.6	12	3VU1340-1TE00	1
1	0.6-1	15	3VU1340-1TF00	
1.6	1-1.6	29	3VU1340-1TG00	
2.4	1.6-2.4	48	3VU1340-1TH00	
4	2.4-4	72	3VU1340-1TJ00	
6	4-6	120	3VU1340-1TK00	
10	6-10	190	3VU1340-1TL00	
16	10-16	300	3VU1340-1TM00	
20	14-20	300	3VU1340-1TN00	

Fuse monitoring motor protection circuit - breakers with 1NO+1NC auxiliary contacts

Rated Current In A	Overload release range A	Shortcircuit release setting A	Type	Std. pkg. (nos.)
0.2	0.2	1.2	3VU1340-1MS00	1

3VU16 Circuit - breakers with 1NO+1NC auxiliary contacts for motor and plant protection

Rated Current In A	Overload release range A	Shortcircuit release setting A	Type ⁵	Recommended 415V Motor Rating in Kw/HP (DOL)	Std. pkg. (nos.)
10	6-10	120	3VU1640-1ML00	4/5.4	1
16	10-16	190	3VU1640-1MM00	7.5/10	
25	16-25	300	3VU1640-1MN00	11/15	
32	22-32	380	3VU1640-1MP00	15/20	
40	28-40	480	3VU1640-1MQ00	18.5/25	
52	36-52	600	3VU1640-1MR00	22/30	

3VU16 Circuit - breakers for plant protection

Rated Current In A	Overload release range A	Shortcircuit release setting A	Type ⁵	Std. pkg. (nos.)
63	45-63	600	3VU1640-1LS00	1

⁵ The 3VU13 and 3VU16 circuit breakers are also available without auxiliary contacts. To order the same, the 8th place of the type number is to be replaced with the digit 0.

Technical Data

According to DIN VDE 0660; IS/IEC 60947-1; IS/IEC 60947-2; IS/IEC 60947-4-1

Type		3VU13		3VU16	
Number of poles		3		3	
Max. rated current I_n					
• motor protection	A	25		52	
• distribution	A	25		63	
Permissible ambient temperature					
• at full rated current	°C	-20 ... +55			
• in storage	°C	-50 ... +80			
Rated operational voltage U_e	V	690			
Rated frequency	Hz	50/60			
Rated insulation voltage U_i	V	750			
Rated impulse withstand voltage U_{imp}	kV	6			
Utilization category					
• to IS/IEC 60947-2 (motor starter protection)		A			
• to IS/IEC 60947-4-1 (motor starters)		AC-3			
Mechanical endurance	Operating cycles				
• up to 25 A	1/h	100,000		100,000	
• 25 A upwards	1/h	–		30,000	
Number of operating cycles/h (on load)	1/h	25		25	
Degree of protection with open terminals/with conductors connected		IP00/IP20			
Temperature compensation	to IS/IEC 60947-4-1	Yes			
Phase failure sensitivity	to IS/IEC 60947-4-1	Yes			
Auxiliary contact for 3VU13 and 3VU16					
Rated operational voltage U_e	AC V	230	400	500	
Rated operational current I_e	A	3	1.5	1.2	
Utilization category		AC-15			
Rated operational voltage U_e DC L/R 200 ms	DC V	24	60	220	
Rated operational current I_e	A	2.3	0.7	0.3	
Utilization category		DC-13			
Wattloss Per Breaker					
		Current rating	Watt	Current rating	Watt
		0.6	5	2.4	8
		4	6	6	7
		6	7	25	14
		25	9	63	23
Cross-section for main conductors					
Solid or stranded	mm ²	2 x (1 ... 6)		1 x 1.5 ... 2 x 16 or 1 x 25 + 1 x 10	
Finely stranded with end sleeve	mm ²	2 x (1 ... 4)		1 x 1.5 ... 2 x 10 or 1 x 16 + 1 x 10	
Cross-sections for auxiliary and control connecting leads					
Solid or stranded	mm ²	1 x 0.5 ... 2 x 2.5			
Finely stranded with end sleeve	mm ²	1 x 0.5 ... 2 x 2.5			

Technical data for accessories:

		3VU13	3VU16
Undervoltage Release			
Consumption During Pick-up	VA/W	10/6	
Consumption During Running	VA/W	4.7/2	
Dropout	V	0.7 to 0.35 X Ue	
Pickup	V	85 to 110% of Ue	
Max Operating Time	ms	20	
Shunt Release			
Consumption	VA/W	10/6	
Max Continuous Rating	Sec	5	
Pickup	V	0.7 to 1.1 X Ue	
Current Limiter for 3VU13			
Rated current In		56 Amps	
Rated Voltage Ue		500 V, 50 / 60 Hz.	
Power Connection	mm ²	2 x (1 to 6)	
Mounting			
		on DIN Rail in any position.	

Table 1 3VU13/3VU16 breaking capacity at 415V

3VU13

Rated current A	0.16-1	1.6	2.4	3.2-4	5-6	8-10	13-16	20-25
Rated Short circuit breaking capacity @ 415V								
Icu kA	100	100	100	100	100	10(50)	6(50)	6(50)
Ics kA	100	100	100	100	100	10(50)	6(50)	6(50)
Maximun back up fuse (gL/gG)								
Diazed A	*	*	*	*	*	80	80	80
NH A	*	*	*	*	*	80	80	80
() Values in bracket are with current limiter; * Fuse not required								
For 3VU13 breakers of ratings 8A & above, in place of fuses, the Current Limiter can be used to increase the S/C breaking capacity.								
Rated Breaking Capacity DC; t = 15ms								
1 Contact	2 Contacts in series	3 Contacts in series	10 kA					
110-150V	220-300V	330-450V						

3VU16

Rated current A	1.6-2.4	4	6	10	16	25	32-63
Rated Short circuit breaking capacity @ 415V							
Icu kA	100	100	100	100	100	100	35
Ics kA	100	100	100	100	100	50	17
Maximun back up fuse (gL/gG); * Fuse not required							
Diazed A	*	*	*	*	*	*	-
NH A	*	*	*	*	*	*	200
Rated Breaking Capacity DC; t = 15ms, upon enquiry							

Characteristic Curves

Tripping time

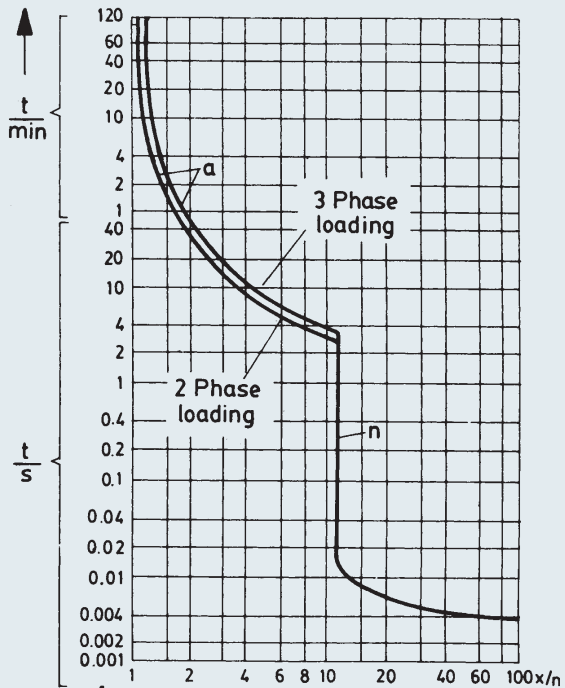

Times set current

Time current characteristics of 3VU13

I peak

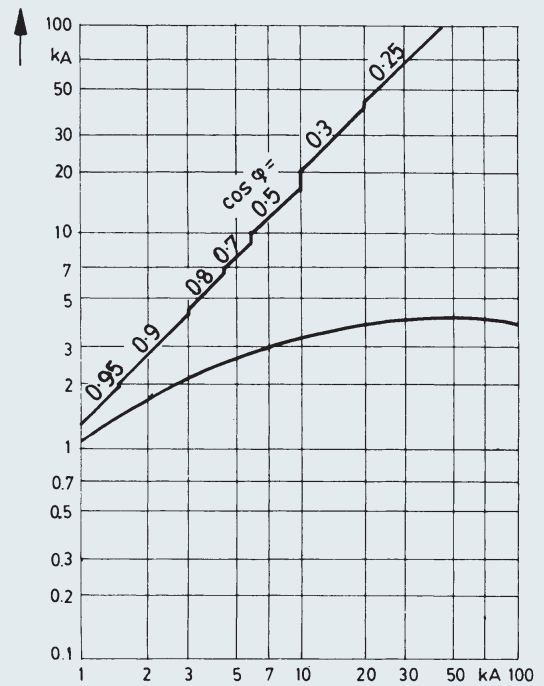

Short circuit current I_k (effective)

Cut off characteristics of 3VU1300-0MK00

Tripping time

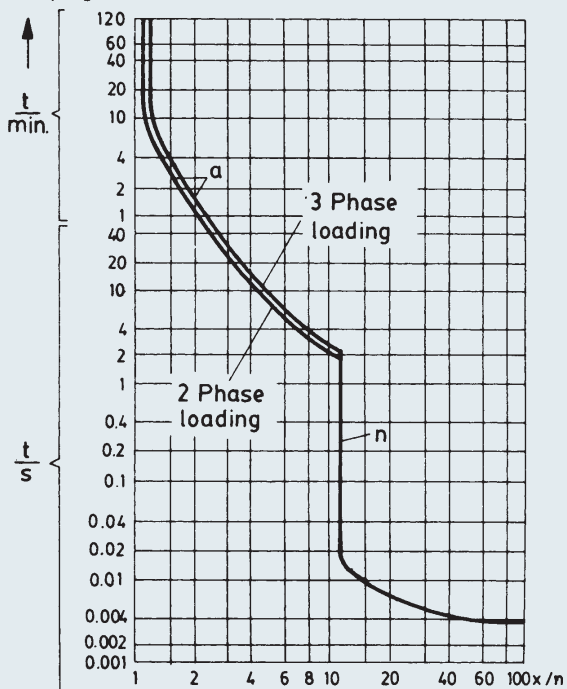

Times set current

Time current characteristics of 3VU16

I peak

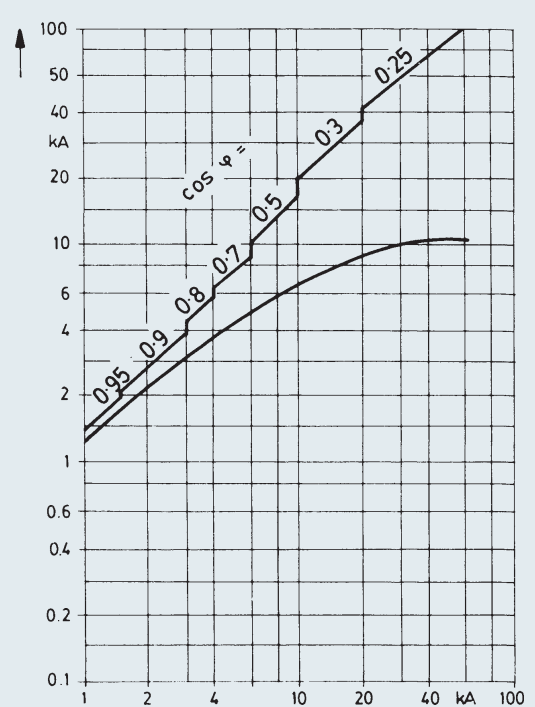

Short circuit current I_k (effective)

Cut off characteristics of 3VU1600-0MN00

Accessories:

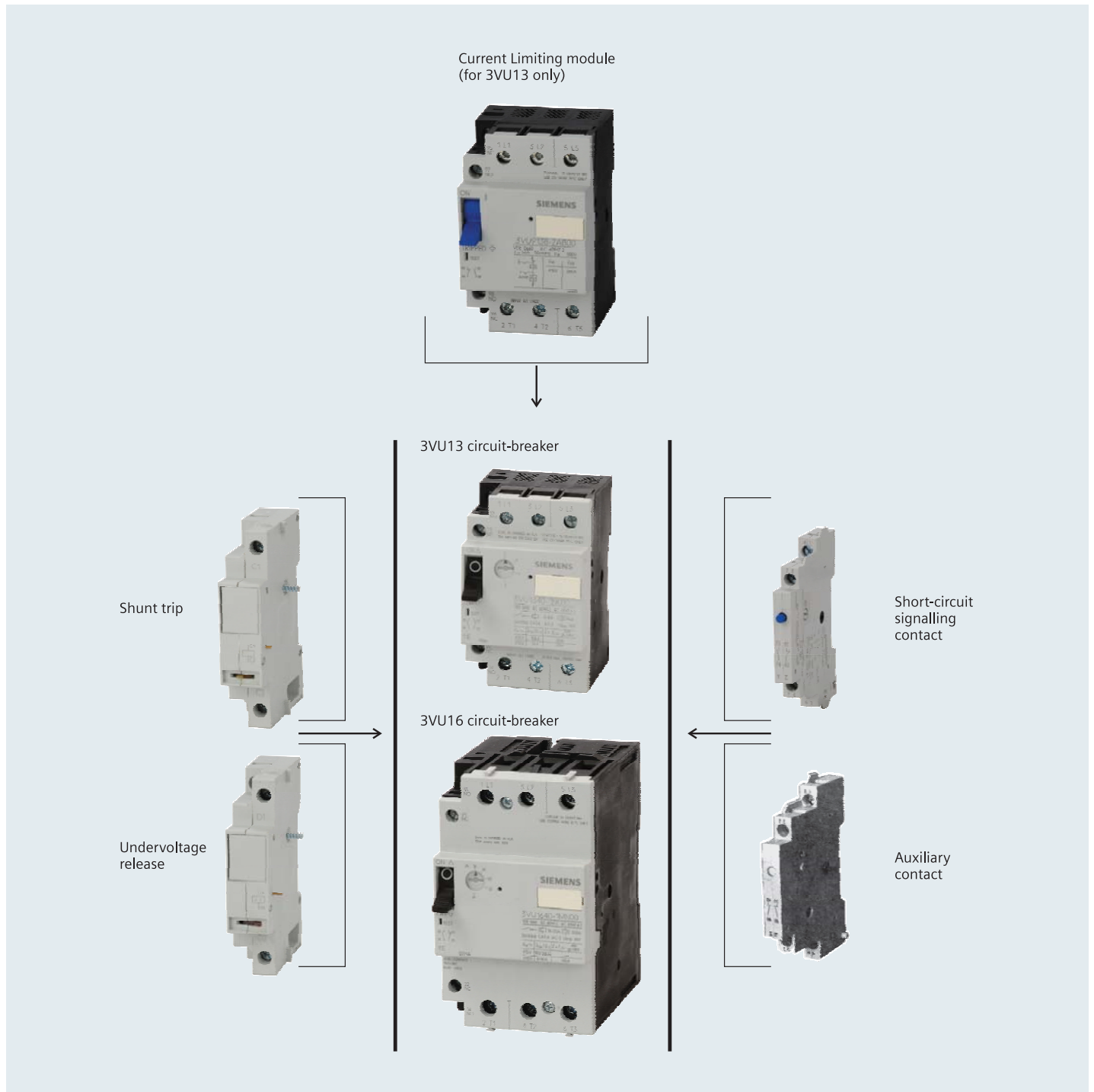

RHS	Alarm contact (1NO + 1NC)	When short circuit (and not overload) occurs, alarm contact 1NO+1NC changes over which can be used to give indication. We need to reset it manually after clearing of short circuit. It performs a function of reclosing lockout.
		and/or
	Auxiliary Contact (1NO + 1NC)	This contact can be added to the MPCB with or without built -in 1NO+1NC contact.
LHS	Shunt Release	Shunt trip is used for remotely tripping the MPCB.
		or
	Undervoltage Release	It trips the MPCB on voltage interruption, preventing the undesirable restart of the motor.
On Top (applicable to 3VU13 only)	Current Limiting Module (independent mounting)	For increasing breaking capacity of 3VU13 to 50kA for 8 - 25A

Current-Limiter



The breaking capacity of 3VU13 is 100kA upto 6A. However for 3VU circuit breakers with rated current of 8A and 10A the short-circuit breaking capacity is 10kA. For circuit breakers with rated current from 16A to 25A the short-circuit breaking capacity is 6kA. In order to enhance the breaking capacity to 50kA, for these ratings (8A to 25A), the current limiter can be used. Thus the need of back up fuses is obviated.

The current limiter is connected in series with 3VU13 MPCB.

When a short circuit occurs, the limiter trips and in turn opens the downstream MPCB. The auxiliary contacts of the current limiter (1NO+1NC) can be used for signaling whether the limiter has tripped or not.

Several MPCBs can also be connected at the output of a current limiter. However the summation of current ratings of individual MPCBs should not be greater than 56A.

Connection diagrams

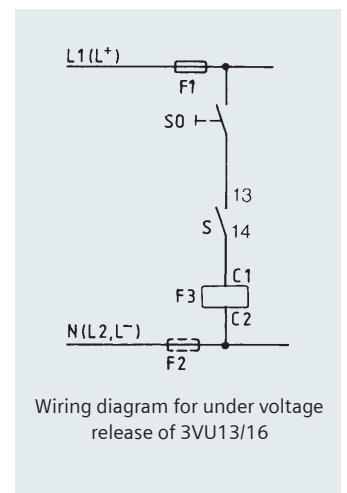
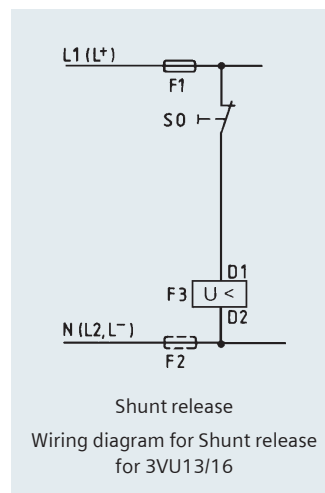
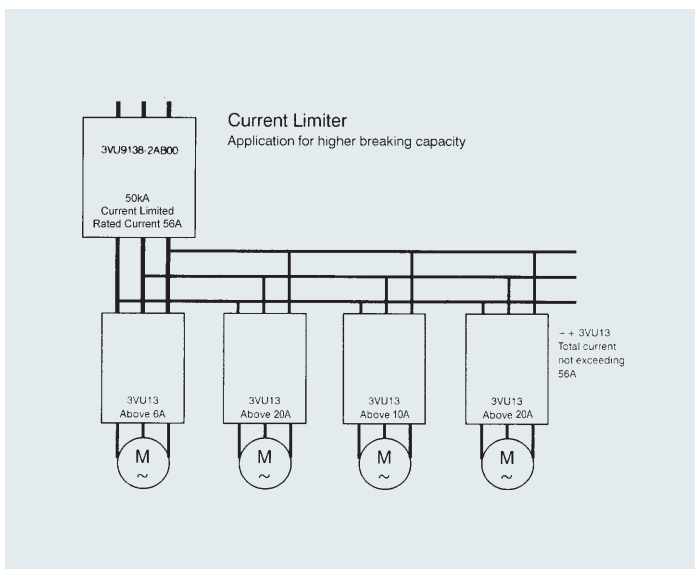
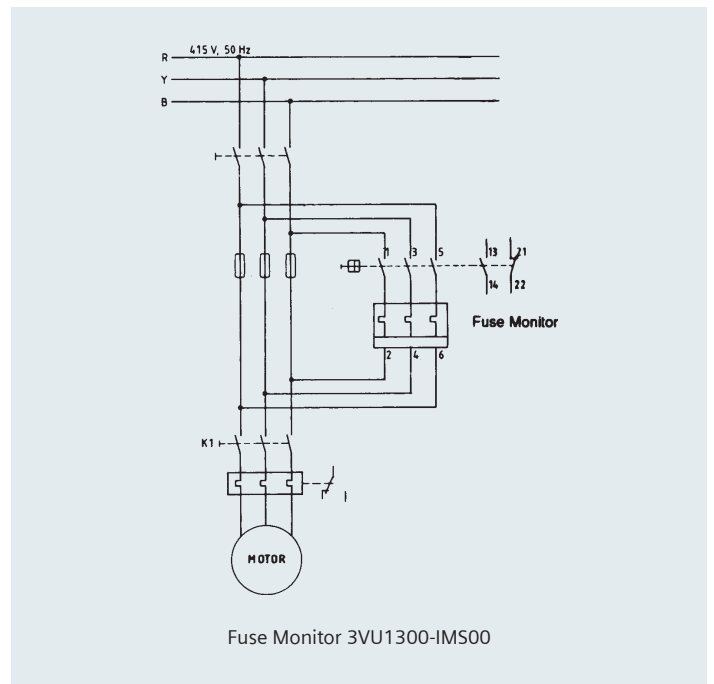
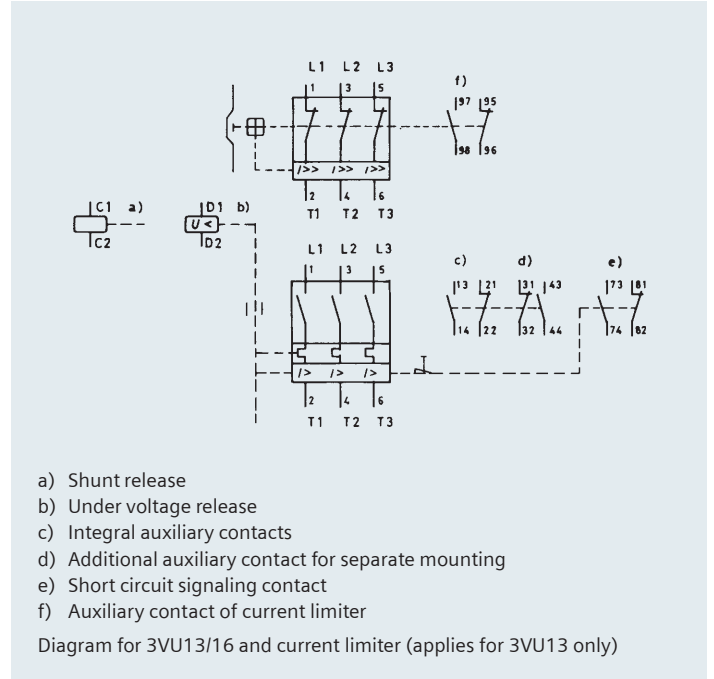

Accessories and ordering data

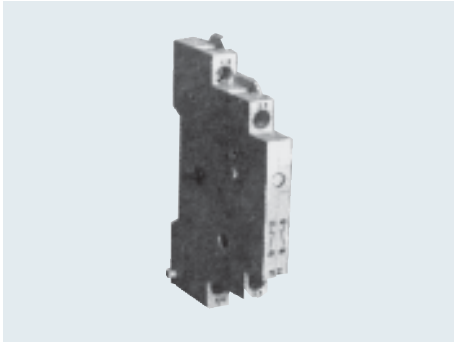

3VU9131-3AA0
Add on Auxiliary block
1NO + NC



3VU9131-7AA0
S/C Trip indicating contacts
1NO + 1NC



3VU9132-0AB15
220/230V 50Hz
Under Voltage release



• 3VU9132-0AB55, 220/230V 50Hz
• 3VU9132-0AB50, 24V/50Hz
• 3VU9132-0AB73, DC 110-240V
Shunt release



3VU9168-0KA00
Padlocking for Toggle
Handle 3VU13/16

3 Ø Insulated Bus-bar System for 3VU13

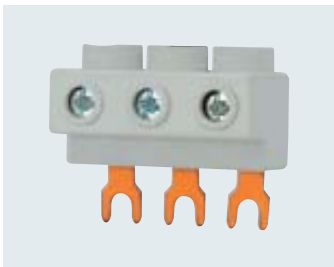

3RV19 25-5AB
3 Ø feed-in Terminal, max rating
63A, for bus-bar system



3VU9135-1AB02
3 Ø Busbars for 2 Breakers
Max. 63Amps

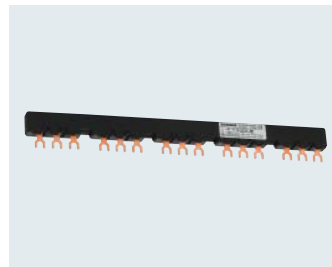

3VU9135-1AB05
3 Ø Busbar for 5 Breakers
Max 63 Amps

Also available

- 3VU9135-1AB03
3 Ø Busbar for 3 breakers
- 3VU9135-1AB04
3 Ø Busbar for 4 Breakers

Door operating mechanism for 3VU13/16*

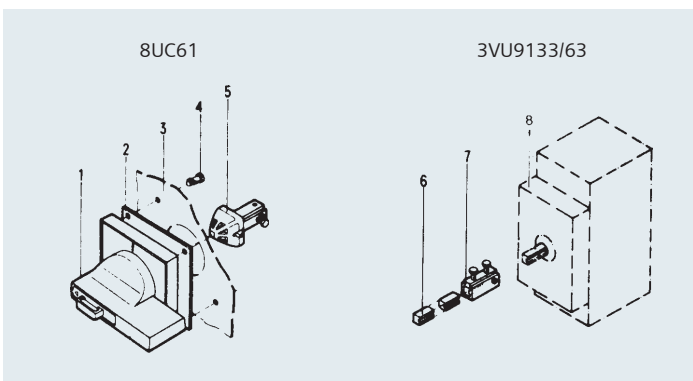

Breaker Operator Kit for 3VU13 - 3VU9133
Breaker Operator Kit for 3VU16 - 3VU9163

1. Handle with masking frame
2. Gasket
3. Door
4. Fixing screws

5. Drive coupling
6. Extension shaft - 300 mm
7. Adapter
8. Breaker operator

* For complete assembly, please order both front drive and breaker operator kit.

Note: All the above accessories have standard package no. = 1

Dimensional Drawings

3VU13 circuit-breakers and accessories

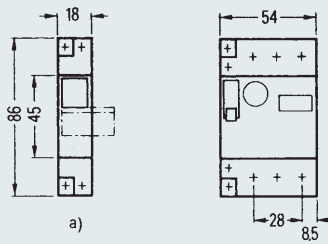

3VU13 circuit-breakers

can be combined with

- a) undervoltage or shunt release and/or
- b) short-circuit signalling switch and/or
- c) auxiliary contacts

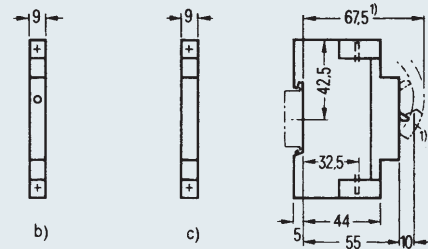

3VU9 138-2AB00 limiter

The limiter has the same dimensions as the standard version of the 3VU13 circuit-breaker

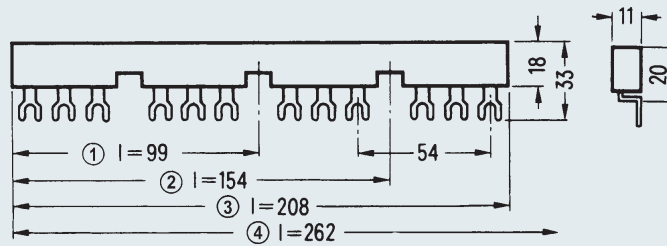

3VU9 135-1AB02, 3VU9 135-1AB03,
3VU9 135-1AB04, 3VU9 135-1AB05
three-phase busbar

- ① For 2 devices: 3VU9 135-1AB02
- ② For 3 devices: 3VU9 135-1AB03
- ③ For 4 devices: 3VU9 135-1AB04
- ④ For 5 devices: 3VU9 135-1AB05

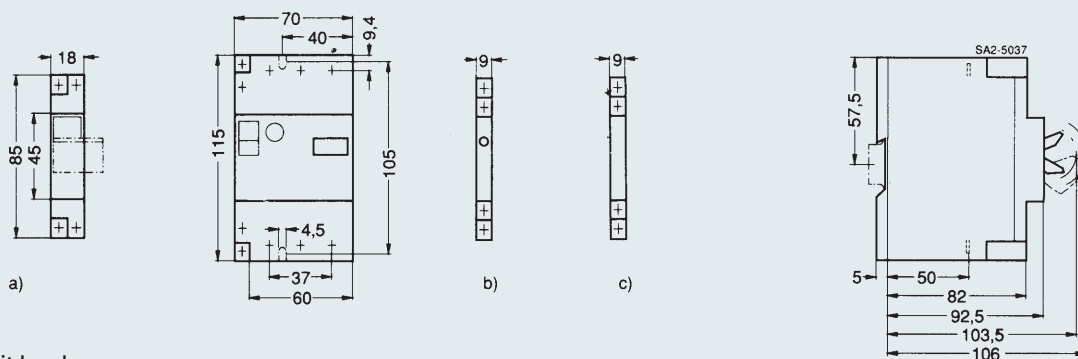

3VU16 circuit-breakers

can be combined with

- a) undervoltage or shunt release and/or
- b) short-circuit signalling switch and/or
- c) auxiliary contacts

Door operating mechanism with extension shaft (300mm) with door interlock & padlocking facilities.

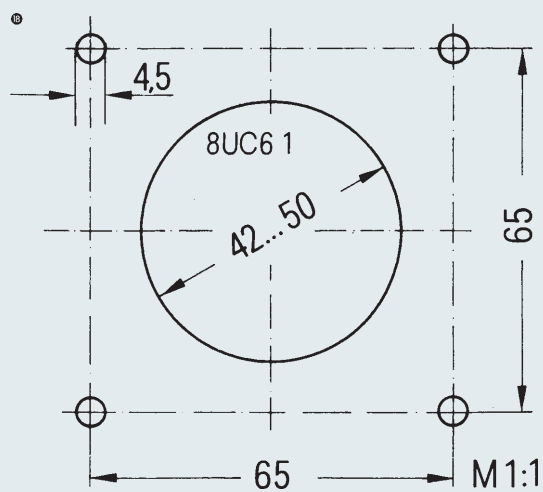
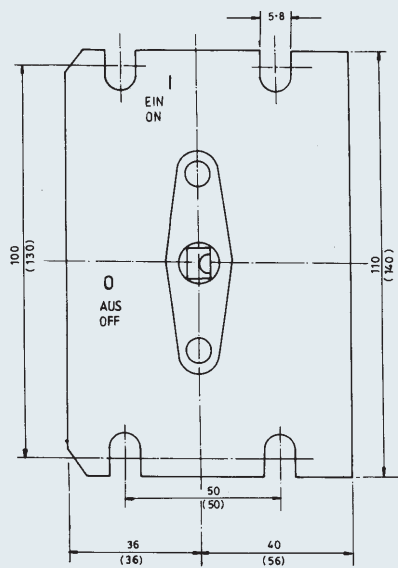

Mounting bracket of 3VU 13/16
 3VU9133-1PA01 for 3VU 13
 3VU9163-1PA02 for 3VU 16

(Figures in bracket are for 3VU 16)
Mounting bracket

Handle

Required space above arc chutes for 3VU13 and 3VU16

Minimum clearance to adjacent parts as well as non-insulated live parts.

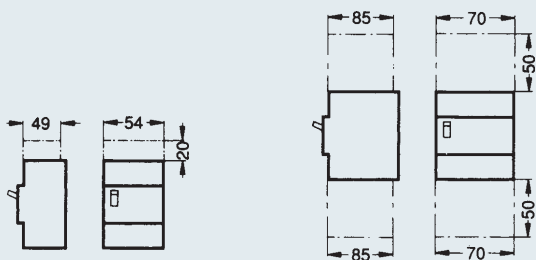

3VU13

3VU16



Starters

Overview

Siemens caters with following types of starters to agricultural and industrial sector.

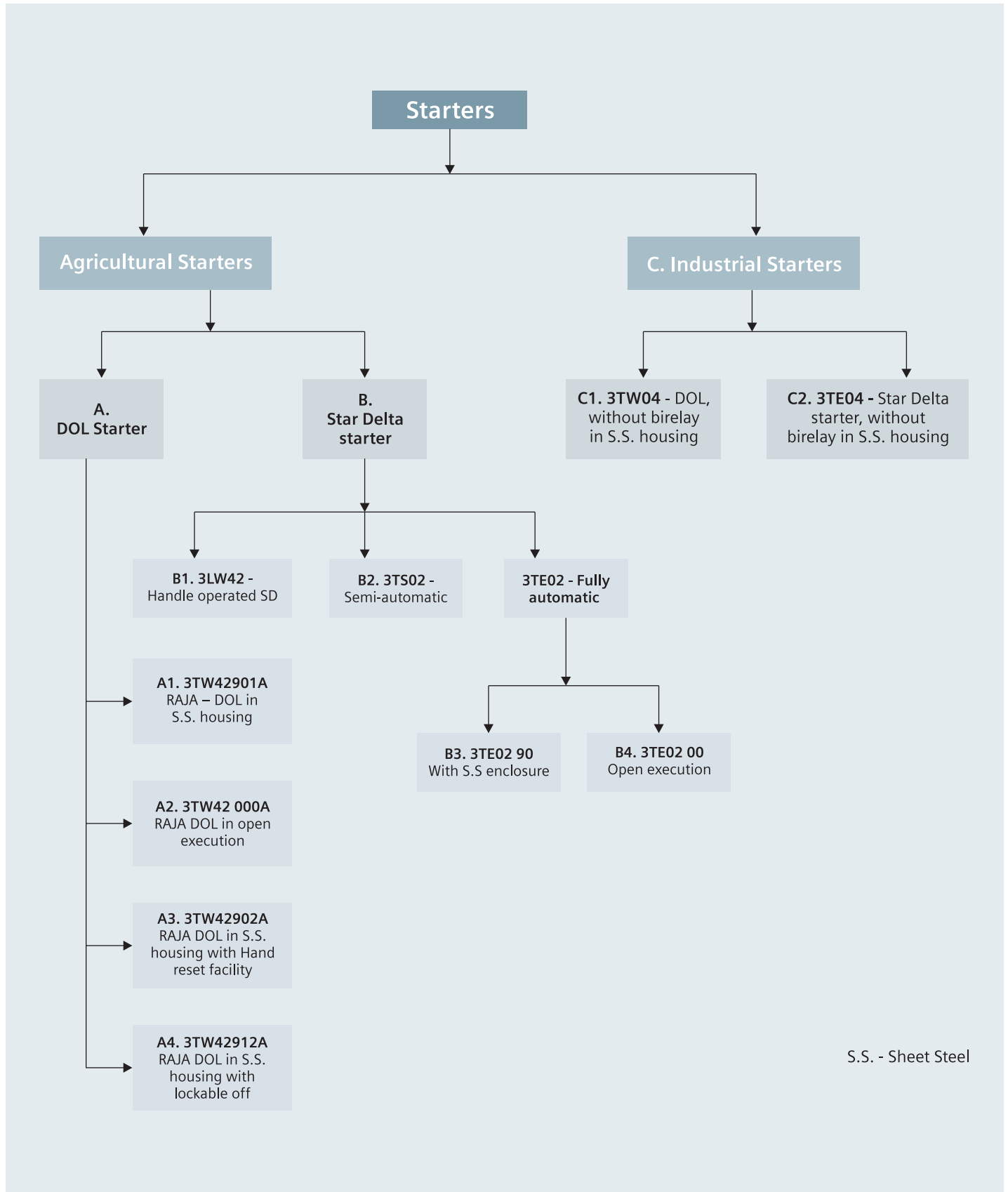

Application

The main purpose of motor starters is to start the electrical motor by switching ON the contactor inside the starter. The relay inside the starter additionally protects the motor in case of overload and single phasing condition. The starter is nothing but a pre-wired assembly of contactor(s), relay and ON-OFF push buttons. Direct on line and star delta are two methods of starting the electric motors which is achieved by our DOL and star delta starter respectively.

Standard

Siemens starters confirms to IS/IEC 60947-4-1

Range

Agricultural starters

3TW42 DOL starters (A1, A2, A3, A4): upto 10Hp

3LW42 Handle operated star delta starters (B1): upto 15Hp

3TS02 Semi-automatic and 3TE02 fully automatic star delta starters (B2, B3, B4): upto 25Hp

Industrial starters

3TW04 DOL and 3TE04 star delta starters (C1, C2): upto 75Hp

Benefits and features

Flexibility

- **Starters with or without enclosure**
Pre-wired DOL as well as star delta starters are available either in open execution or in sheet steel enclosure.
- **Industrial starters without relay**
Industrial DOL as well as star delta starters have provision for mounting relay but the relay is not provided in the starter. Thus offering flexibility of selecting 3UA relay range as per customers requirement.

Reliability

- **Wide band coil voltage**
Agricultural DOL starters are having option of 200-400 V and agricultural star delta starters are having option of 230-400 V coil voltage which takes care of wide fluctuations in the supply voltage occurring especially in the remote places.

High performance

- **In-built single phasing protection**
In case of phase loss the current through the other two windings increases by 1.732 times the rated current of the motor. The current now flows only through the 2 bimetallic strips which should produce the required force on the tripping mechanism. This needs higher currents for longer time. As current is not too high so the relay might take higher time to trip. This can cause damage to the motor. Similar condition happens in case of phase unbalance. To take care of these conditions our birelays provided in the starters are constructed such that they offer a built-in single phasing protection using differential slider principle.



Ordering data

A1. DOL Starter in sheet steel housing, incl. birelay with single phasing protection

Motor rating at 415V, 3ph, 50Hz		Type ¹⁾ (DOL)	Relay range A	Std. pkg. (nos.)
HP	kW			
0.33	0.25	3TW42 90-1A.64	0.63-1	1
0.75	0.55	3TW42 90-1A.66	1-1.6	
1	0.75	■ 3TW42 90-1A.68	1.6-2.5	
1.5	1.1	3TW42 90-1A.69	2-3.2	
2	1.5	■ 3TW42 90-1A.71	3.2-5	
3	2.2	■ 3TW42 90-1A.72	4-6.3	
5	3.7	■ 3TW42 90-1A.74	6.3-10	
–	–	■ 3TW42 90-1A.75	8-12.5	
7.5	5.5	■ 3TW42 90-1A.77	10-16	
10	7.5	■ 3TW42 90-1A.78	12.5-20	

¹⁾ Enter code for coil voltage, 50Hz (B for 200-400V, W for 415V)

A2. Starter in open execution, incl. birelay with single phasing protection

Motor rating at 415V, 3ph, 50Hz		Type ¹⁾ (DOL)	Relay range A	Std. pkg. (nos.)
HP	kW			
0.33	0.25	3TW42000A.64	0.63-1	1
0.75	0.55	3TW42000A.66	1-1.6	
1	0.75	3TW42000A.68	1.6-2.5	
1.5	1.1	3TW42000A.69	2-3.2	
2	1.5	3TW42000A.71	3.2-5	
3	2.2	3TW42000A.72	4-6.3	
5	3.7	3TW42000A.74	6.3-10	
–	–	3TW42000A.75	8-12.5	
7.5	5.5	3TW42000A.77	10-16	
10	7.5	3TW42000A.78	12.5-20	

¹⁾ Enter code for coil voltage, 50Hz (B for 200-400V, W for 415V)

A3. Starter with lockable off, in sheet steel housing, incl. birelay with single phasing protection

Motor rating at 415V, 3ph, 50Hz		Type ¹⁾ (DOL)	Relay range A	Std. pkg. (nos.)
HP	kW			
0.33	0.25	3TW42912A.64	0.63-1	1
0.75	0.55	3TW42912A.66	1-1.6	
1	0.75	3TW42912A.68	1.6-2.5	
1.5	1.1	3TW42912A.69	2-3.2	
2	1.5	3TW42912A.71	3.2-5	
3	2.2	3TW42912A.72	4-6.3	
5	3.7	3TW42912A.74	6.3-10	
–	–	3TW42912A.75	8-12.5	
7.5	5.5	3TW42912A.77	10-16	
10	7.5	3TW42912A.78	12.5-20	

¹⁾ Enter code for coil voltage, 50Hz (B for 200-400V, W for 415V)

A4. Starter with hand reset facility, in sheet steel housing, incl. birelay with single phasing protection

Motor rating at 415V, 3ph, 50Hz		Type ¹⁾ (DOL)	Relay range A	Std. pkg. (nos.)
HP	kW			
0.33	0.25	3TW42902A.64	0.63-1	1
0.75	0.55	3TW42902A.66	1-1.6	
1	0.75	3TW42902A.68	1.6-2.5	
1.5	1.1	3TW42902A.69	2-3.2	
2	1.5	3TW42902A.71	3.2-5	
3	2.2	3TW42902A.72	4-6.3	
5	3.7	3TW42902A.74	6.3-10	
–	–	3TW42902A.75	8-12.5	
7.5	5.5	3TW42902A.77	10-16	
10	7.5	3TW42902A.78	12.5-20	

¹⁾ Enter code for coil voltage, 50Hz (B for 200-400V, W for 415V)

B1. Handle-operated star delta starter in sheet steel housing, incl. birelay with single phasing protection

Motor rating at 415V, 3ph, 50Hz		Type ¹⁾ (HSD)	Relay range	Std. pkg. (nos.)
HP	kW			
5	3.7	3LW42 90-0A.72	4-6.3	1
10	7.5	3LW42 90-0A.74	6.3-10	
12.5	9.3	3LW42 90-0A.75	8-12.5	
15	11	3LW42 90-0A.77	10-16	

¹⁾ Enter code for coil voltage, 50Hz (B for 200-400V, W for 415V)

B2. Semi-automatic star delta starter in sheet steel housing, incl. birelay with single phasing protection

Motor rating at 415V, 3ph, 50Hz		Type ²⁾ (SASD)	Relay range	Std. pkg. (nos.)
HP	kW			
12.5	9.3	3TS02 90-0A.75	8-12.5	1
15	11	3TS02 90-0A.77	10-16	
20	15	3TS02 90-0A.78	12.5-20	
25	18.5	3TS02 90-0A.79	16-25	

²⁾ Enter code for coil voltage, 50Hz (D for 230-400V, W for 415V)

B3. Automatic star delta starter in sheet steel housing, incl. birelay with single phasing protection

Motor rating at 415V, 3ph, 50Hz		Type ²⁾ (ASD)	Relay range	Std. pkg. (nos.)
HP	kW			
12.5	9.3	■ 3TE02 90-0A.75	8-12.5	1
15	11	■ 3TE02 90-0A.77	10-16	
20	15	■ 3TE02 90-0A.78	12.5-20	
25	18.5	■ 3TE02 90-0A.79	16-25	

²⁾ Enter code for coil voltage, 50Hz (D for 230-400V, W for 415V)

B4. Automatic star delta starter in open execution

Motor rating at 415V, 3ph, 50Hz		Type ²⁾ (DOL)	Relay range	Std. pkg. (nos.)
HP	kW			
12.5	9.3	3TE02000A.75	0.63-1	1
15	0.55	3TE02000A.77	1-1.6	
20	0.75	3TE02000A.78	1.6-2.5	
25	1.1	3TE02000A.79	2-3.2	

²⁾ Enter code for coil voltage, 50Hz (D for 230-400V, W for 415V)

C1. DOL starter in sheet steel housing (without birelay - to be ordered separately)

Motor rating at 415V, 3ph, 50Hz		Type ³⁾ (DOL)	Birelay (recommended)	Std. pkg. (nos.)
HP	kW			
20	15	■ 3TW04 94-2A..	3UA55 (20-32A)	1
25	18.5	■ 3TW04 95-2A..	3UA55 (25-36A)	
30	22	■ 3TW04 96-2A..	3UA58 (32-50A)	
40	30	■ 3TW04 97-2A..	3UA58 (40-57A)	
50	37	■ 3TW04 98-2A..	3UA58 (57-70A)	
75	55	■ 3TW05 90-2A..	3UA5830 (85-105A)	

³⁾ Enter code for coil voltage, 50Hz ("RO" for 415V, "PO" for 230V)

C2. Automatic star delta starter in sheet steel housing (without birelay)

Motor rating at 415V, 3ph, 50Hz		Type ³⁾ (ASD)	Birelay (recommended)	Std. pkg. (nos.)
HP	kW			
30	22	■ 3TE04 94-2A..	3UA55 (16-25A)	1
40	30	■ 3TE04 94-2A..	3UA55 (20-32A)	
50	37	■ 3TE04 95-2A..	3UA55 (32-40A)	
60	45	■ 3TE04 96-2A..	3UA58 (32-50A)	
75	55	■ 3TE04 97-2A..	3UA58 (40-57A)	

³⁾ Enter code for coil voltage, 50Hz ("RO" for 415V, "PO" for 230V)

Relays and contactors used in the starters:

	MLFB	AC3 Rating @ 415V	Used in starter
Contactor	3TW0 290-0A.51 [#]	20	A1 to A4, B1
	3TW0 311-0A*51	25	B2 to B4
	3TW0 320-0A*51	25	B2 to B4
Relay	3UW5 002.. ⁵	16/20	All A & B

Coil codes for contactor 3TW02

Coil voltage V, 50Hz	200-400	415
Code	B	W

* Coil codes for contactor 3TW03

Coil voltage V, 50Hz	230-400	220	415
Code	D	M	W

⁵ Coil codes for relay 3UW5:

Relay range	0.63-1	1-1.6	1.6-2.5	2-3.2	3.2-5	4-6.3	6.3-10	8-12.5	10-16	12.5-20	16-25
Code	0J	1A	1C	1D	1F	1G	1J	1K	2A	2B	2C

C. Industrial starter (starters w/o relay)









The 3TF contactor is available and 3UA relays are recommended.

Spares for starters

Spares for 3TW42 / 3LW42

CONTACTOR	3TW0 290-0A.51	
RELAY	3UW5002.. ⁵	
ON Actuator	3TX0 204-1YA0	
OFF Actuator	3TX0 204-1YB0	
Reset Actuator for HSD	3TX0 204-1YR0	
Coil	3TX0 203-0Y.6 [#]	
Arc chamber	3TX0 202-0YA0	
Main contact kit 1pole	3TX0 200-0YA1	
Main contact kit 3pole	3TX0 200-0YA0	
Moving contact carrier	3TX0 200-0YD0	
Aux fixed contact	3TX0 200-1YB0	
Aux moving contact	3TX0 200-1YC0	
On/off contact	3SX1 551-1YA	
Switch for HSD starter	3LA0 204-4YB	

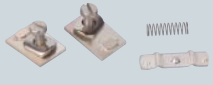
Spares for 3TE02

CONTACTOR	3TW0 311-0A*51	
CONTACTOR	3TW0 320-0A*51	
RELAY	3UW5002.. ^s	
Main contact kit 3pole	3TX0 300-0YA0	
Main contact kit 1pole	3TX0 300-0YA1	
Coil	3TX0 303-0Y*6	
Aux fixed contact	3TX0 300-1YB0	
Aux fixed contact	3TX0 300-1YD0	
Aux moving contact	3TX0 300-1YC0	

Spares for other starters:

On/Off actuators	3SX1 552-1YA	
On/Off contact	3SX1 551-1YA	

Single line diagram SLD

DOL - in S.S. Housing SLD- 3phase motor

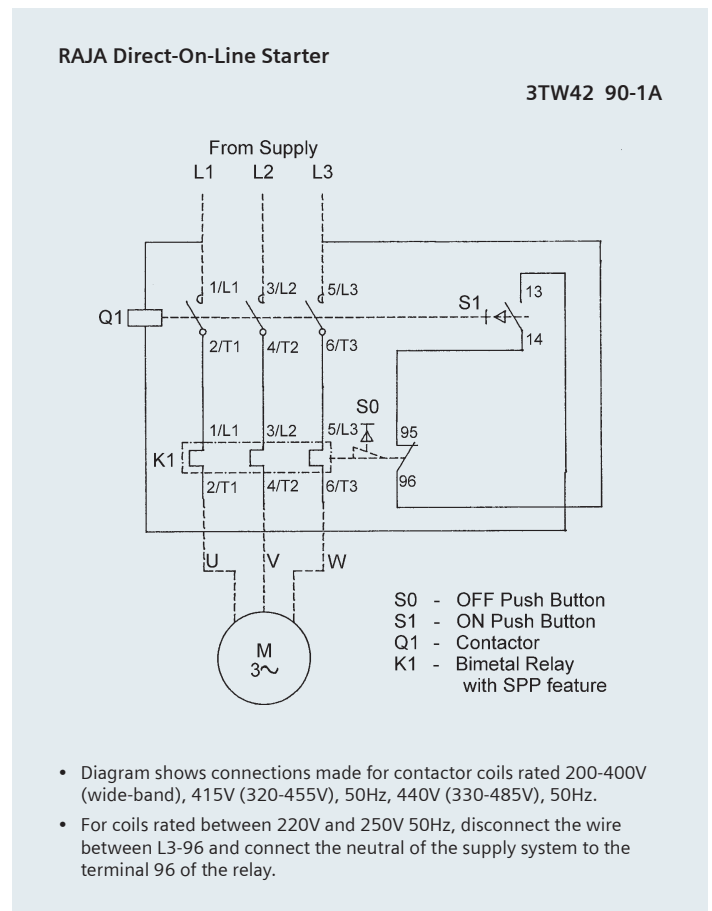

DOL - in S.S. Housing SLD- 1phase motor

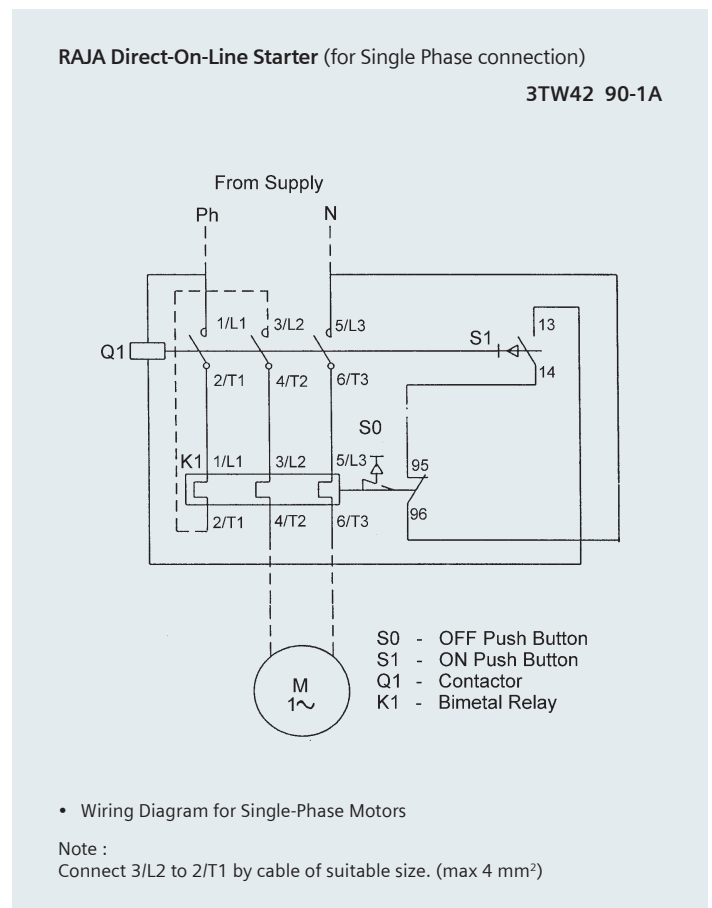

DOL - open execution SLD – 3phase motor

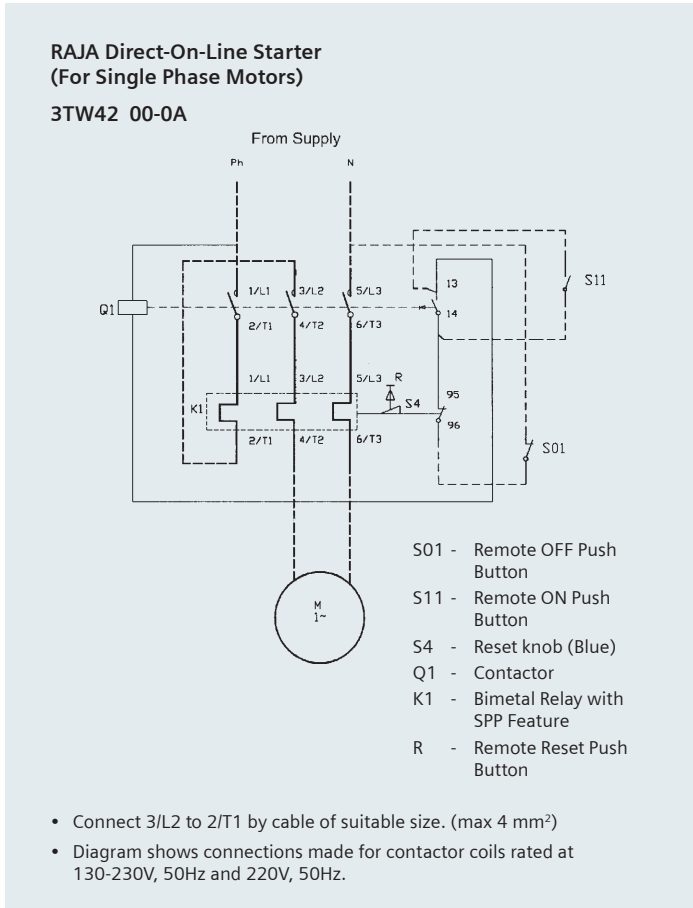

DOL – open execution SLD – 1phase motor

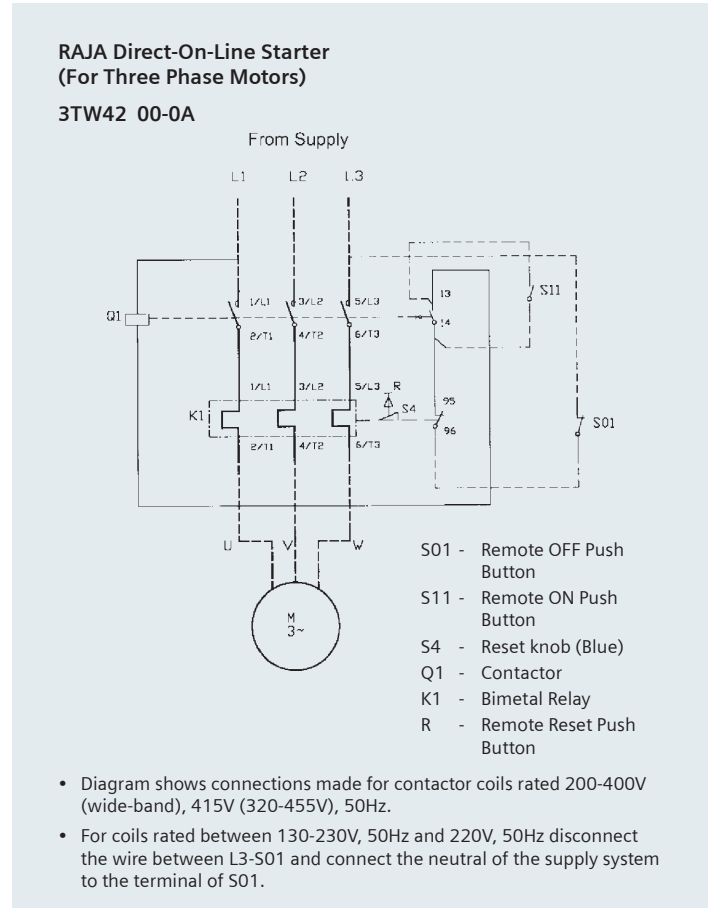

DOL – Remote reset - SLD

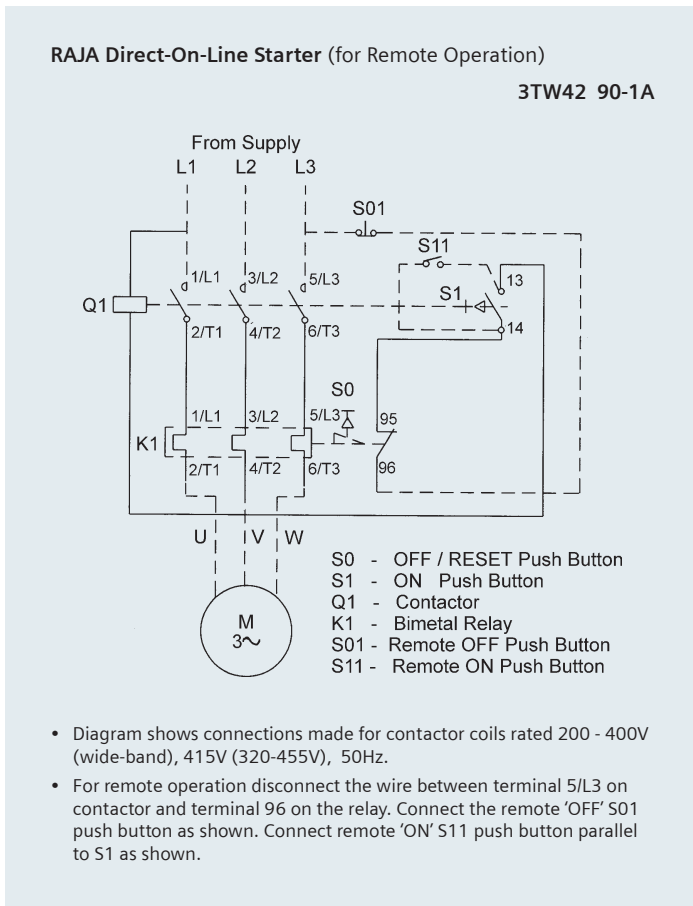

Handle Star delta Starter

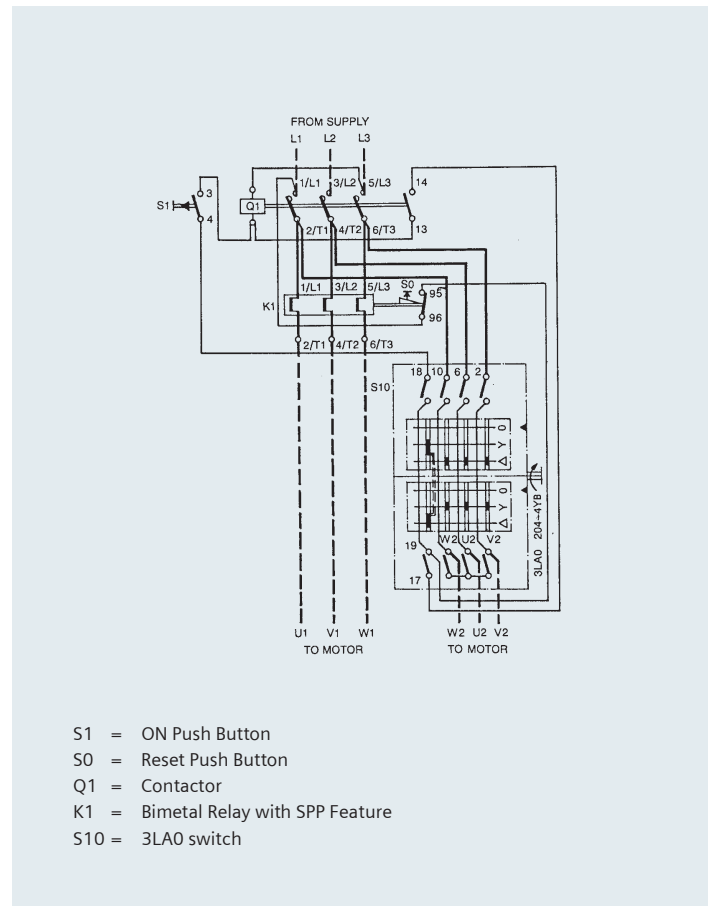

Star delta Starter

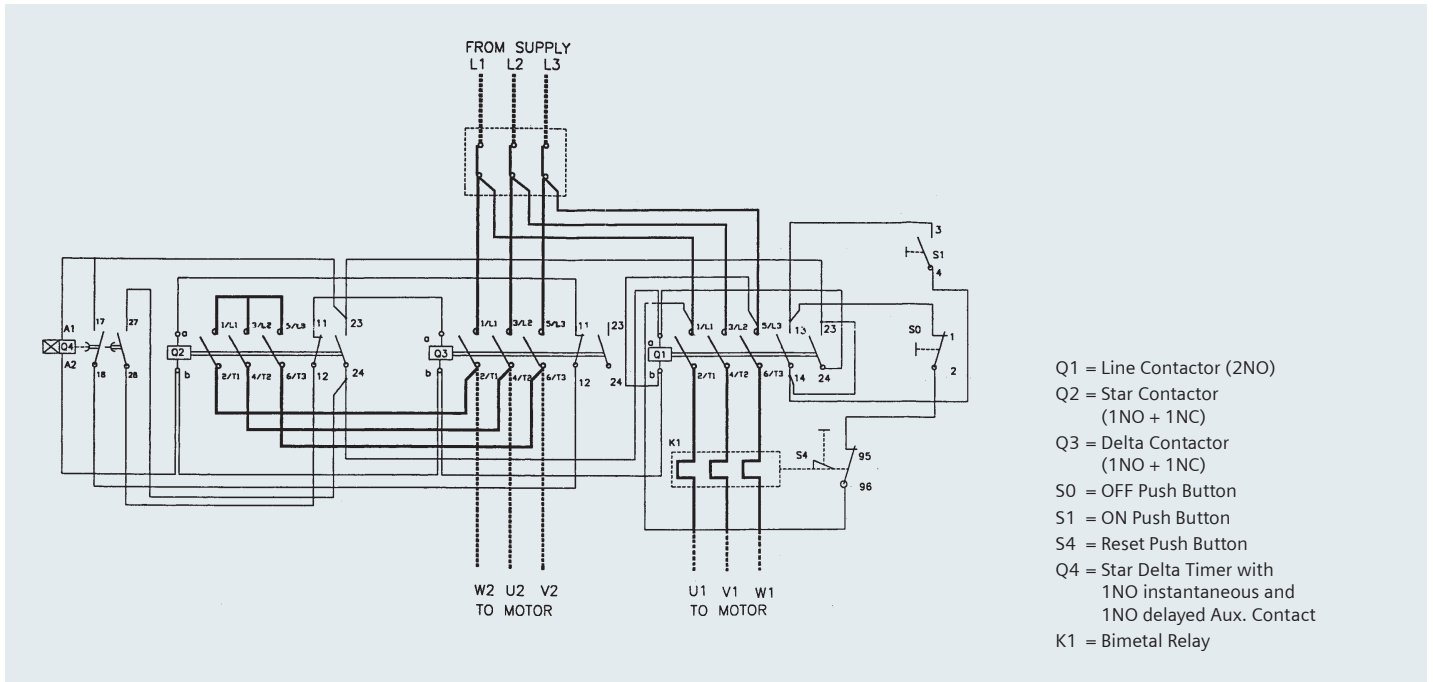

Dimensional drawings

A1: DOL starter in enclosure
 A3: DOL with hand reset

A4: DOL with lockable off (here a small lock comes on the off push button which is not shown here below)

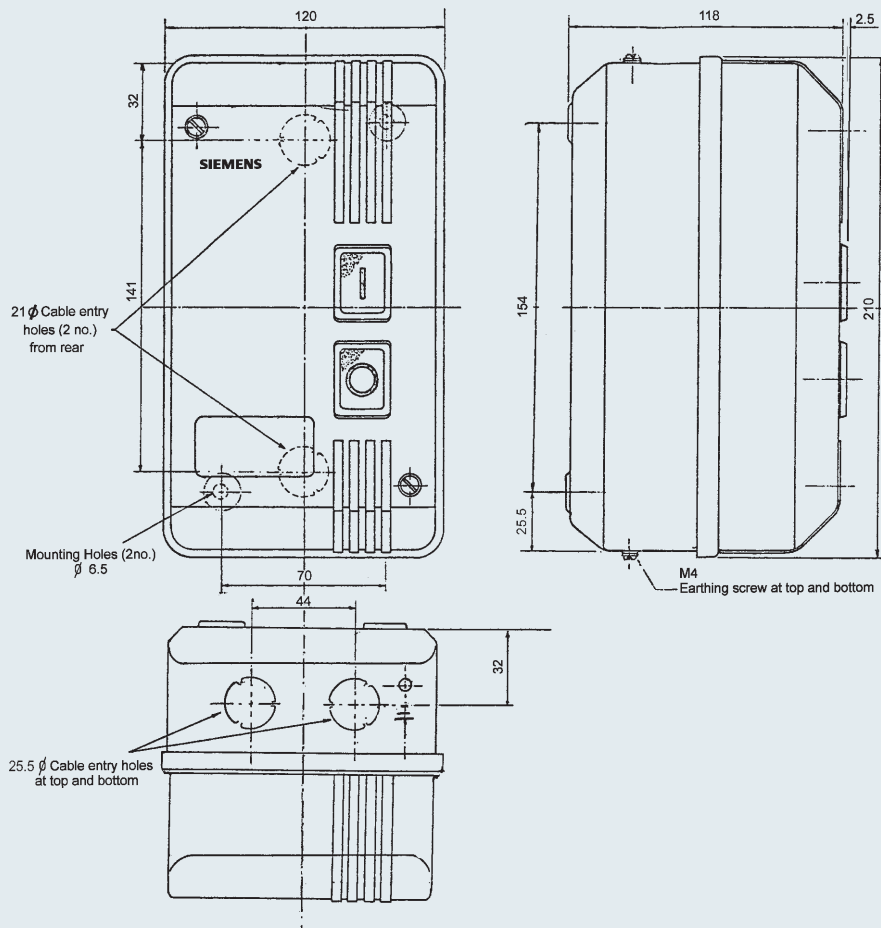

* Mounting dimensions 154 x 70

A2: DOL starter in open execution (contactor and relay are mounted on a plate)

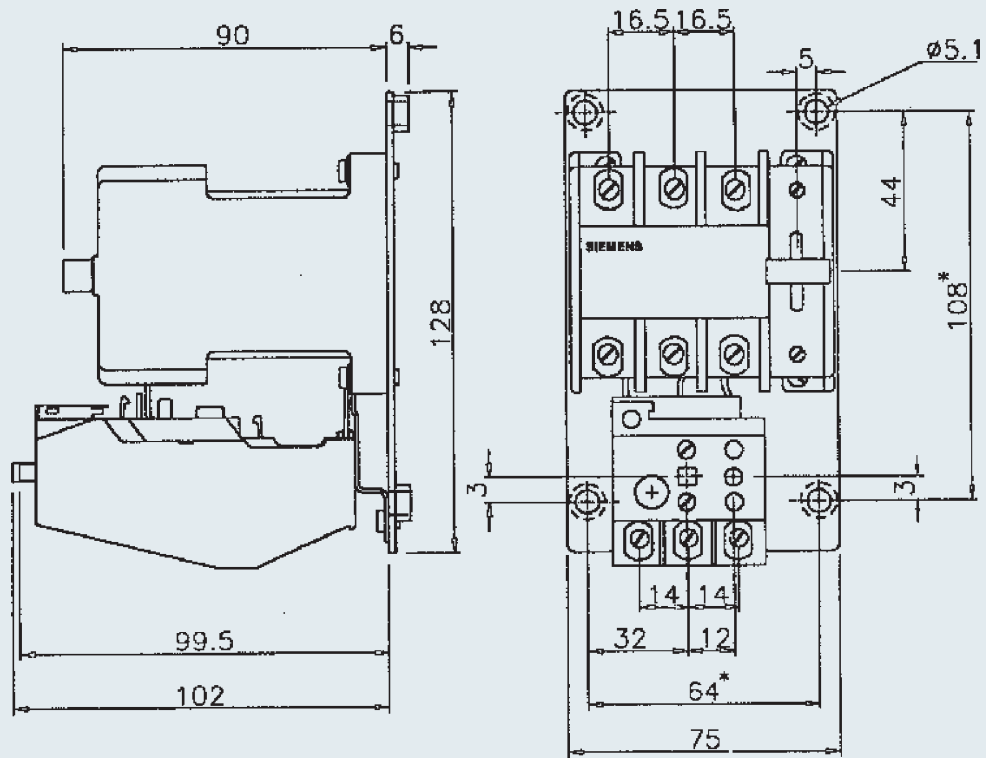

* Mounting dimensions 64 x 108 (Use M4 screws)

B1: Handle operated Star delta starter

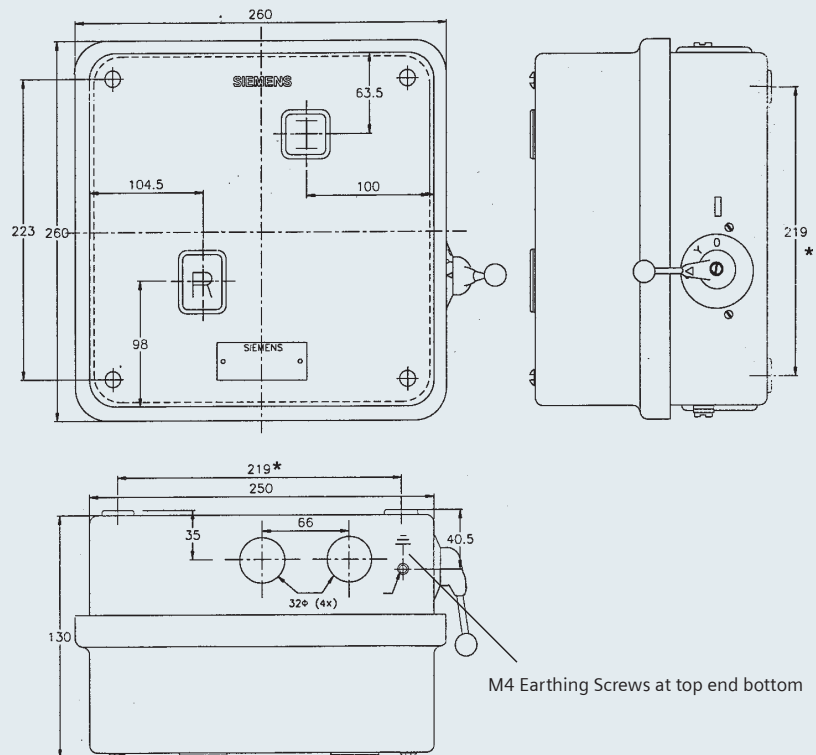

M4 Earthing Screws at top end bottom

* Mounting dimensions 219 x 219
Use M4 screws for mounting

B2: Semi automatic star delta starter and
 B3: Fully automatic star delta starter

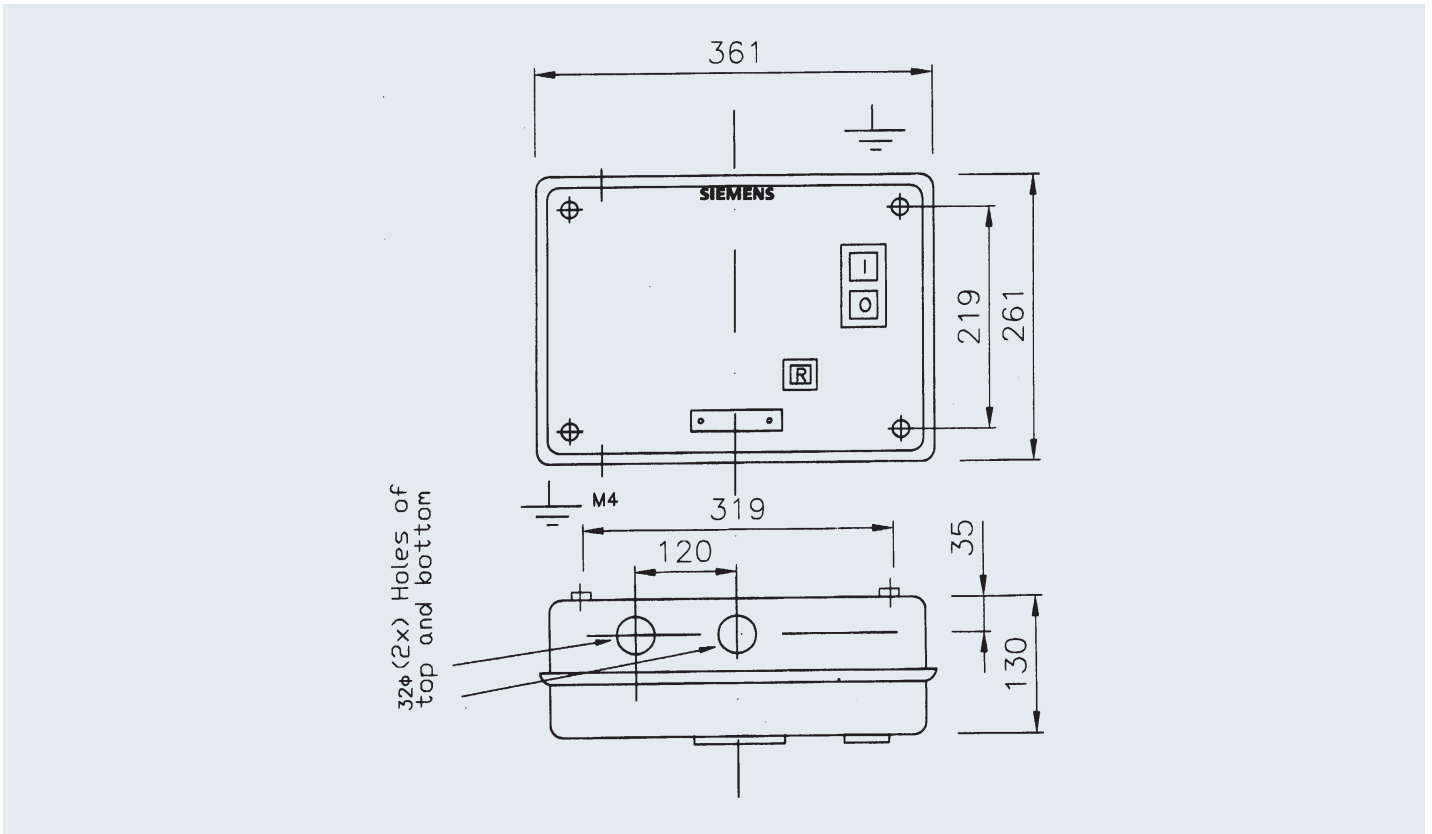

B4. Fully automatic star delta starter in open execution

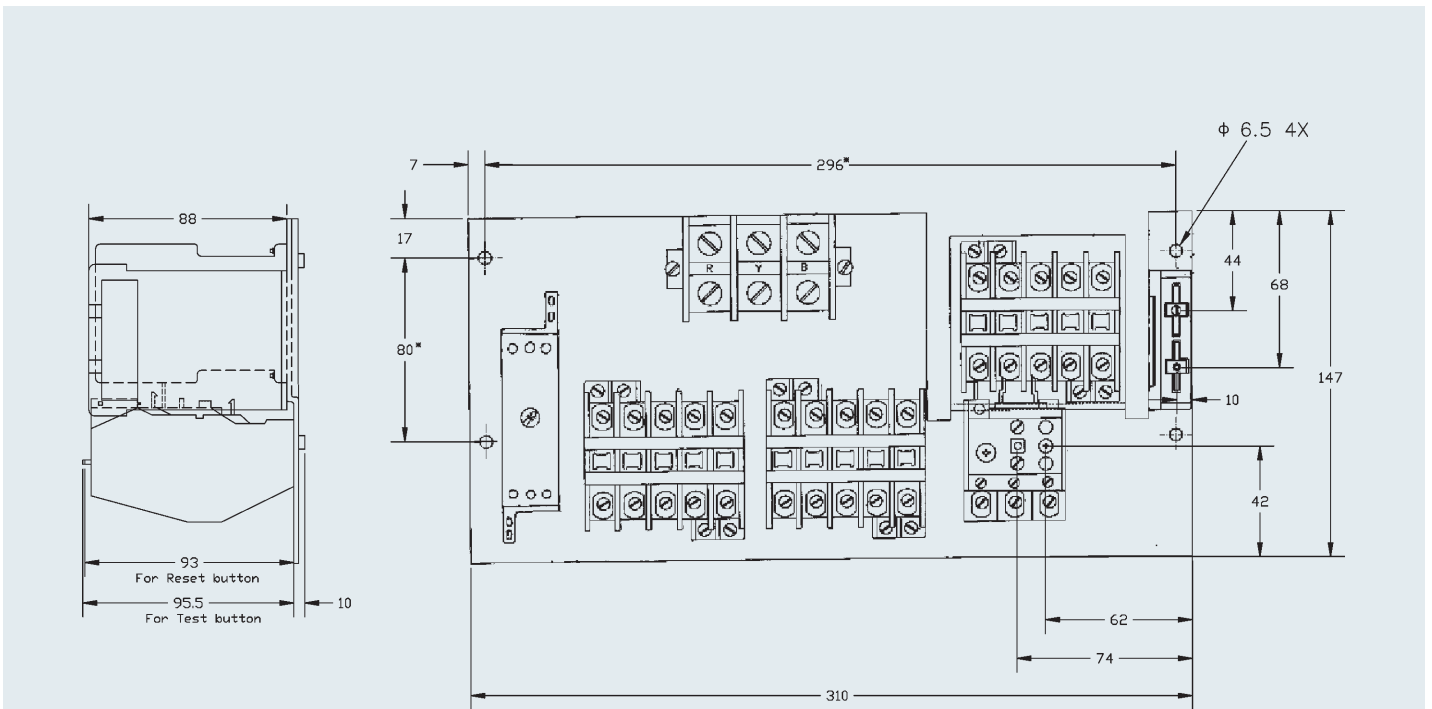

*Mounting Dimensions 296X80 Use M5 screws

C1: DOL without relay

3TW04 95-2A..

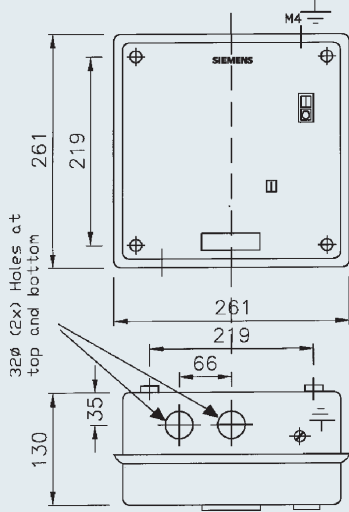

3TW04 96-2A..
3TW04 97-2A..
3TW04 98-2A..

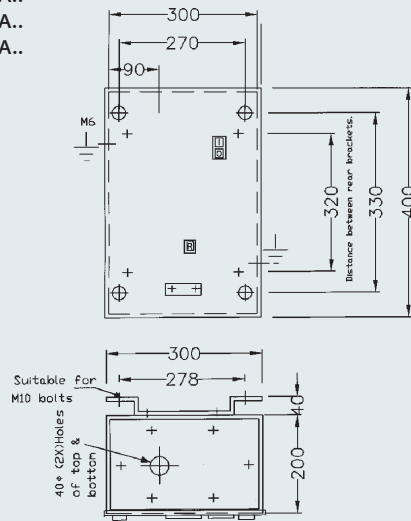

3TW05 90-2A..
3TW05 91-2A..

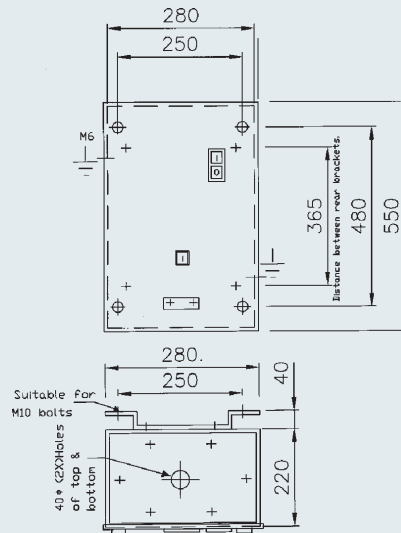

C2.

3TE04 94-2A..
3TE04 95-2A..

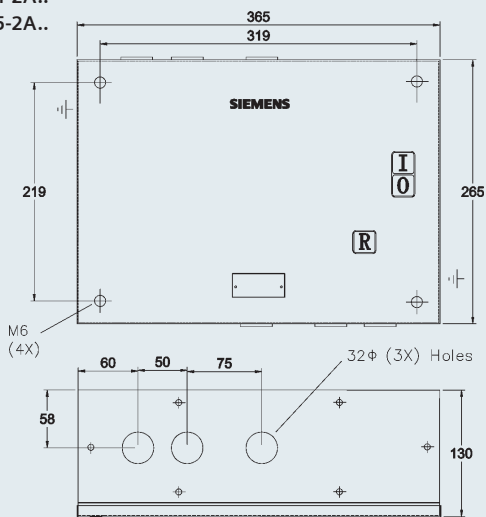

3TE04 96-2A..
3TE04 97-2A..

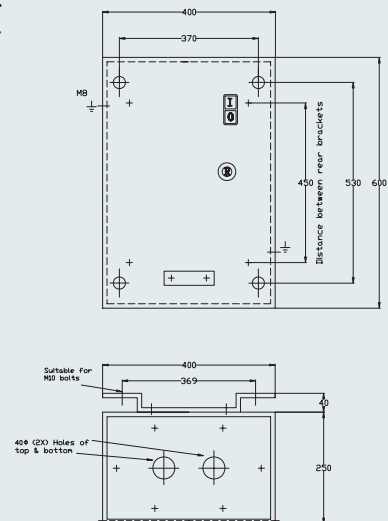

Useful technical information

Method of starting

A. DOL starting method:

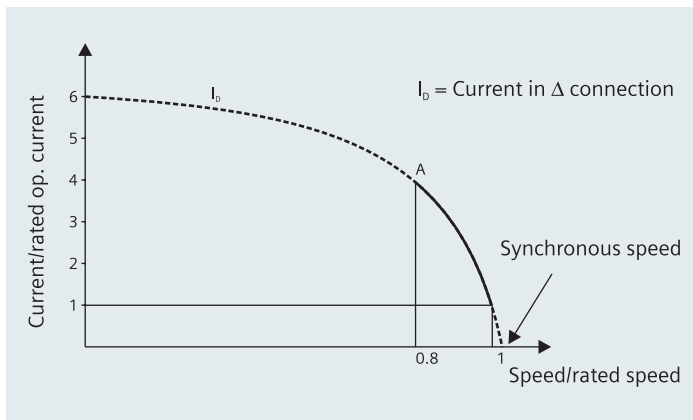

The most economical and popular method of starting squirrel cage induction motors, is direct-on-line, where the starter is connected directly across the supply. However, the starting current at the moment of switching Direct-on-line can be as high as 6-8 times the rated current.

Advantages: High starting torque, shorter starting time, simple construction and wiring, space saving etc.

Disadvantages: High starting current

Types:

Agricultural Starters

A1. RAJA DOL starter

Construction



Contactor:

The DOL starter up to 10 HP is fitted with 3TW02 contactor. This contactor is specially designed by Siemens considering the requirements of industry as well as agriculture. Considering the specific need of the agricultural pump set applications, Siemens has designed a special wide band coil (200- 400V). This coil operates reliably even when there is wide voltage fluctuation. The contact rating of this contactor is 20 A. This high contactor rating has made RAJA starter the most suitable starter for applications where current for given HP is higher than that of the conventional motors' e.g.. Submersible pumps etc.

Bimetal Overload Relay:

The RAJA direct-on-line starter is fitted with 3UW50 relay. These relays are computer calibrated and therefore, offer accurate protection. The main benefit of this bimetal relay is the built-in single phasing protection in addition to the overload protection. This relay is automatic reset type and can not be reset by hand.

Push buttons

Push buttons are used for switching 'ON' and 'OFF' the starter.

Operation:

In DOL starting, the 'ON' push button is pressed, which energizes the contactor coil, thus switching on the circuit. When the OFF' push button is pressed, the contactor is de-energized, switching off the circuit. The bimetal relay under normal functioning of motor plays no active part in the starter. But under overload, single phasing or locked rotor conditions of Motor, the bimetal relay cuts-off the supply to the contactor coil, tripping the circuit. The contactor itself provides the necessary 'no-voltage' protection in so far as it will drop out in the case of a supply failure, and for restarting on resumption of supply, the 'ON' push button will have to be pressed again.

A2. RAJA DOL stater in open execution:



This starter is exactly same as DOL starter with sheet steel housing except the enclosure and push buttons. The contactor and birelays are wired and mounted on the plate. It is expected that the user provides for the housing for this starter and also for the ON-OFF arrangement by way of push buttons or any other means.

A3. RAJA DOL starter with hand reset:

This starter is exactly same as RAJA DOL starter with sheet steel housing but in this case the relay needs to be reset manually. The OFF button on the housing is also used as reset button for resetting the relay after overload.



A4. DOL starter with lockable off:



This starter is exactly same as RAJA DOL starter with sheet steel housing but the relay needs to be reset manually by pressing OFF PB. Locking arrangement is provided for OFF push button; so starter can't be switched ON, inadvertently.

B. Star delta starting method:

In star delta starting, initially the motor windings are connected in star. This reduces the starting current by $1/\sqrt{3}$ rd of the full load current also the voltage by $(1/\sqrt{3})$ of the rated value. As the torque is proportional to the square of the voltage, the starting torque also get reduced to $1/3$ rd of it's full load value. Once the motor attains approximately 80% of the rated speed, the windings get connected in the delta formation.

Thus by star delta starting, the starting current is reduced to 2 to 2.5 times the rated current unlike DOL starting, where it is 7 to 8 times of the rated current.

Advantages: low starting current

Disadvantages: Low / medium starting torque, longer starting time, less simpler construction and wiring, requires more space etc.

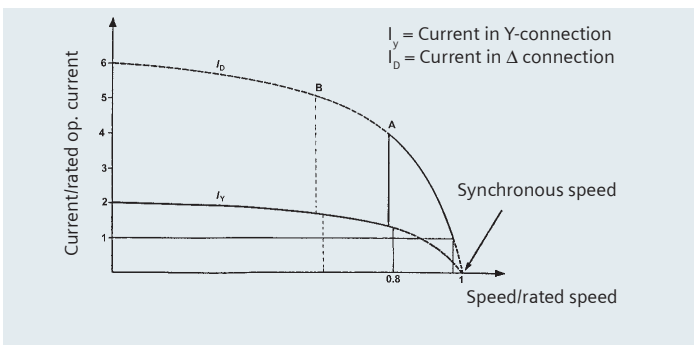

B1. Handle Operated Star Delta Starter (3LW42)



In this starter, the changeover from 'star' to 'delta' is done manually through a control switch.

Construction:

It consists of a star-delta switch (3LAO), contactor (3TW02), an overload relay (3UW50), "Reset" push button and a safety 'ON' push button.

Operation:

To start the motor, move the 3LAO switch handle from 'O' position to 'star' (Y) position with the right hand and press the start - (I) push button with your left hand. The motor starts and when it has almost come to its rated speed (indicated when the motor hum reaches a steady pitch), turn the handle to 'delta' position, still ensure to keep the push button pressed. After switching to delta, the push button and the switch handle can be released. To stop the motor, bring the handle of the switch to 'O' position. If the starter trips automatically due to any fault, the switch handle is first to be brought to 'O' position and the bimetal relay has to be reset.

B2. Semi automatic Star-Delta Starter (3TS02)

In this starter, the changeover from 'star' to 'delta' is done manually by pressing ON push button.



Construction:

It consists of three contactors (3TW03), bimetal overload relay (3UW50), and push buttons (ON-OFF, Reset) for control command.

Operation:

To start the motor, ON' push button is pressed and the same is hold for 6 to 8 sec (starting time of the motor). After 6-8 sec, it is left. After this, motor automatically changes over from star to delta. The OFF push button has been provided to switch off the entire circuit.

B3. Fully automatic Star-Delta Starter (3TE02)

In this starter, the changeover from 'star' to 'delta' is done automatically after a preset time by using a timer.



Construction:

It consists of three contactors (3TW03), bimetal overload relay (3UW50), electronic timer (3RP) for automatic changeover from 'star' to 'delta' and push buttons (ON-OFF, Reset) for control command.

Operation:

To start the motor, ON' push button is pressed, the line contactor and the star contactor switch-on connecting motor windings in star formation on reduced voltage. After the preset time, the timer automatically switches off the 'star' contactor and switches 'ON' the 'delta' contactor, thus after the starting period, the motor runs on full voltage. The OFF push button has been provided to switch off the entire circuit.

B4. Fully automatic star delta starter in open execution



This starter is exactly same as fully automatic starter in sheet steel housing expect the enclosure and push buttons. The contactor and birelays are wired and mounted on the plate.

C. Industrial Starter:

C1. DOL (3TW04):



This starter is similar to RAJA DOL starter with sheet steel housing (3TW42901A). In order to offer flexibility of selecting exact 3UA relay range by the customer, this starter has only provision for mounting the bi-relay but the birelay is not provided in the starter. Customer is required to select the suitable bi-relay and mount it in the starter before putting it in service.

C2. Star Delta (3TE04):



This starter is similar to star delta starter with sheet steel housing (3TE02). In order to offer flexibility of selecting exact 3UA relay range by the customer, this starter has only provision for mounting the bi-relay but the birelay is not provided in the starter. Customer is required to select the suitable bi-relay and mount it in the starter before putting it in service.

Fuse protected selection type 2, Iq = 50kA, IS/IEC: 60947-4-1

- The selection is valid only for complete Siemens combinations i.e. SDF + DIN Fuse + Contactor + Bi-Relay (+ timer).
- In case this combination is changed to accommodate another brand/rating of SDF/DIN Fuse/Contactor/BMR, it shall be the responsibility of the person making such a change to assure type 2 performance.
- Selection is for normal starting conditions with starting time ≤ 6 seconds. For heavy starting applications (e.g. ID/FD fans, reciprocating compressors, ball mills etc.), please consult Siemens.
- At 60°C service temperature the bi-relay has to be derated. The bi-relay can be used upto the maximum current setting indicated. For example - A bi-relay with setting 32-50A, at 60°C can be used only upto 47A. This however does not mean that at 60°C, the 50A setting corresponds to 47A. It means that, the bi-relay should not be set beyond 47A.
- The electronic star-delta timer type 3RP should be used in star-delta feeders.
- SDF: Switch Disconnecter Fuse. All fuses are DIN HRC type.
- Tested Type 2 combinations
- Low LCC = Low Life Cycle Cost

Direct-on-line feeder, for Low LCC

SL Motor kW/HP 415V, 3ph, 50Hz	Motor IL Amp	SDF		HRC Fuse		Contactor		Bi-Relay		Bi-Relay	
		Type	Rating	Type 3NA7	Amp	Type	Amp	Type (50°C)	Set-Range Amp	Type (60°C)	Available Set-Range Amp
0.37/0.5	1	3KL811	20	3NA7804	4	3TF30	9	3UA5000-0K	0.8 - 1.25	3UA5000-0K	0.8 - 1.17
0.55/0.75	1.3	3KL811	20	3NA7804	4	3TF30	9	3UA5000-1A	1 - 1.6	3UA5000-1A	1 - 1.5
0.75/1	1.9	3KL811	20	3NA7801	6	3TF30	9	3UA5000-1B	1.25 - 2	3UA5000-1C	1.6 - 2.3
1.1/1.5	2.6	3KL811	20	3NA7801	6	3TF30	9	3UA5000-1D	2 - 3.2	3UA5000-1D	2 - 3
1.5/2	3.7	3KL811	20	3NA7803	10	3TF30	9	3UA5000-1E	2.5 - 4	3UA5000-1E	2.5 - 3.7
2.2/3	4.8	3KL811	20	3NA7805	16	3TF30	9	3UA5000-1F	3.2 - 5	3UA5000-1G	4 - 5.9
3.7/5	7.8	3KL811	20	3NA7807	20	3TF30	9	3UA5000-1H	5 - 8	3UA5000-1J	6.3 - 9.4
5.5/7.5	11.2	3KL812	32	3NA7810	25	3TF31	12	3UA5000-1K	8 - 12.5	3UA5000-1K	8 - 11.7
7.5/10	16	3KL812	32	3NA7812	32	3TF32	16	3UA5200-2A	10 - 16	3UA5200-2B	12.5 - 18.7
9.3/12.5	19	3KL815	63	3NA7820	50	3TF34	32	3UA5500-2B	12.5 - 20	3UA5500-2C	16 - 23.4
11/15	20.8	3KL815	63	3NA7820	50	3TF34	32	3UA5500-2C	16 - 25	3UA5500-2C	16 - 23.4
15/20	28	3KL815	63	3NA7822	63	3TF34	32	3UA5500-2D	20 - 32	3UA5500-2D	20 - 30
18.5/25	34	3KL815	63	3NA7822	63	3TF35	38	3UA5500-2Q	25 - 36	3UA5500-2R	32 - 37.4
22/30	40	3KL821	100	3NA7824	80	3TF46	45	3UA5800-2FZ1	32 - 50	3UA5800-2FZ1	32 - 47
30/40	53	3KL821	100	3NA7830	100	3TF47	63	3UA5800-2TZ1	40 - 57	3UA5800-2PZ1	50 - 59
37/50	65	3KL822	125	3NA7832	125	3TF477	70	3UA5800-2VZ2	57 - 70	3UA5800-2VZ2	57 - 65.5
45/60	78	3KL822	125	3NA7832	125	3TF49	85	3UA5800-8YZ1	70 - 95	3UA5800-8YZ1	70 - 88.9
55/75	96	3KL823	160	3NA7836	160	3TF50	110	3UA5830-5C	85 - 105	3UA5830-5C	85 - 98.2
75/100	131	3KL831	200	3NA7140	200	3TF51	140	3UA6230-5A	85 - 135	3UA6230-5B	115 - 168
90/125	156	3KL832	250	3NA7144	250	3TF52	170	3UA6230-5B	115 - 180	3UA6230-5B	115 - 168
110/150	189	3KL832	250	3NA7144	250	3TF53	205	3UA6230-5C	160 - 250	3UA6230-5C	160 - 234
132/180	227	3KL833	315	3NA7252	315	3TF54	250	3UA6230-5C	160 - 250	3UA6230-5C	160 - 234
160/215	271	3KL834	400	3NA7260	400	3TF55	300	3UA6230-5D	200 - 320	3UA6230-5D	200 - 299
200/270	339	3KL841	500	3NA7365	500	3TF56	400	3UA6230-5E	250 - 400	3UA6230-5E	250 - 374
250/335	398	3KL841	500	3NA7365	500	3TF57	475	3UA6830-3F	320 - 500	3UA6830-5F	320 - 468

Star-Delta feeder, for Low LCC

SL Motor kW/HP 415V, 3ph, 50Hz	Motor		SDF		HRC Fuses		Contactor Line/Delta		Contactor Star		Bi-Relay		Bi-Relay		Timer Type
	IL Amp	Iph Amp	Type	Rating	Type 3NA7	Amp	Type	Amp	Type	Amp	Type (50°C)	Set-Range Amp	Type (60°C)	Available Set-Range Amp	
2.2/3	4.8	2.8	3KL811	20	3NA7801	6	3TF30	9	3TF30	9	3UA5000-1D	2-3.2	3UA5000-1D	2-3	3RP15
3.7/5	7.8	4.5	3KL811	20	3NA7803	10	3TF30	9	3TF30	9	3UA5000-1F	3.2-5	3UA5000-1F	3.2-4.7	3RP15
5.5/7.5	11.2	6.5	3KL811	20	3NA7805	16	3TF30	9	3TF30	9	3UA5000-1H	5-8	3UA5000-1H	5-7.5	3RP15
7.5/10	16	9.2	3KL811	20	3NA7807	20	3TF31	12	3TF30	9	3UA5000-1J	6.3-10	3UA5000-1J	6.3-9.4	3RP15
9.3/12.5	19	11	3KL812	32	3NA7810	25	3TF31	12	3TF30	9	3UA5000-1K	8-12.5	3UA5000-1K	8-11.7	3RP15
11/15	20.8	12	3KL812	32	3NA7810	25	3TF31	12	3TF30	9	3UA5000-1K	8-12.5	3UA5000-2S	10-13.6	3RP15
15/20	28	16.2	3KL812	32	3NA7812	32	3TF33	22	3TF32	16	3UA5200-2B	12.5-20	3UA5200-2B	12.5-18.7	3RP15
18.5/25	34	19.7	3KL815	63	3NA7820	50	3TF34	32	3TF34	32	3UA5500-2B	12.5-20	3UA5500-2C	16-23.4	3RP15
22/30	40	23.2	3KL815	63	3NA7820	50	3TF34	32	3TF34	32	3UA5500-2C	16-25	3UA5500-2D	22-30	3RP15
30/40	53	30.6	3KL815	63	3NA7822	63	3TF34	32	3TF34	32	3UA5500-2D	20-32	3UA5500-2Q	25-33.7	3RP15
37/50	65	37.5	3KL821	100	3NA7824	80	3TF35	38	3TF34	32	3UA5500-2R	32-40	3UA5500-8M	36-45	3RP15
45/60	78	45	3KL821	100	3NA7830	100	3TF46	45	3TF34	32	3UA5800-2FZ1	32-50	3UA5800-2FZ1	32-47	3RP15
55/75	96	55.4	3KL821	100	3NA7830	100	3TF47	63	3TF34	32	3UA5800-2TZ1	40-57	3UA5800-2PZ1	50-59	3RP15
75/100	131	75.6	3KL823	160	3NA7836	160	3TF49	85	3TF47	63	3UA5800-8YZ1	70-95	3UA5800-8YZ1	70-88.9	3RP15
90/125	156	90.1	3KL823	160	3NA7836	160	3TF50	110	3TF47	63	3UA5830-5B	70-95	3UA5830-5C	85-98.2	3RP15
110/150	189	109	3KL831	200	3NA7140	200	3TF50	110	3TF50	110	3UA5830-5D	95-120	3UA5830-5D	95-112	3RP15
132/180	227	131.1	3KL832	250	3NA7144	250	3TF51	140	3TF50	110	3UA6230-5B	115-180	3UA6230-5B	115-168	3RP15
160/215	271	156.5	3KL833	315	3NA7252	315	3TF52	170	3TF50	110	3UA6230-5B	115-180	3UA6230-5B	115-168	3RP15
200/270	339	195.7	3KL834	400	3NA7260	400	3TF54	250	3TF52	170	3UA6230-5C	160-250	3UA6230-5C	160-234	3RP15
250/335	398	229.8	3KL841	500	3NA7260	400	3TF54	250	3TF54	250	3UA6230-5C	160-250	3UA6230-5D	200-299	3RP15

Fuseless selection type 2, Iq = 50kA, IS/IEC: 60947-4-1

- The selection is valid only for complete Siemens combinations i.e. MPCB / MCCB + contactor + bi-relay (+timer).
- In case this combination is changed to accommodate another brand/rating of MPCB/MCCB/contactor/BMR, it shall be the responsibility of the person making such a change to assure Type 2 performance.
- Selection is for **normal starting** conditions with starting time ≤ 6 seconds. For **heavy starting** applications (e.g. ID/FD fans, reciprocating compressors, ball mills etc.), please consult Siemens.
- The **electronic star-delta timer type 3RP** should be used in star-delta feeders.
- Truly tested Type 2 combinations at neutral authorities.
- Low LCC = Low life cycle cost

Direct-on-line feeder, for low LCC

SL motor		Circuit breaker		Contactor		Bi-relay	
kW/HP 415V, 3ph, 50Hz	IL A	Type	A	Type	A	Type (50°C)	Range (A)
0.37/0.5	1	3RV11 21-0KA10	1.25	3TF30	9	#	0.9 - 1.25
0.55/0.75	1.3	3RV11 21-1AA10	1.6	3TF30	9	#	1.1 - 1.6
0.75/1	1.9	3RV11 21-1BA10	2	3TF30	9	#	1.4 - 2
1.1/1.5	2.6	3RV11 21-1DA10	3.2	3TF31	12	#	2.2 - 3.2
1.5/2	3.7	3RV11 21-1EA10	4	3TF32	16	#	2.8 - 4
2.2/3	4.8	3RV11 21-1FA10	5	3TF32	16	#	3.5 - 5
3.7/5	7.8	3RV11 21-1HA10	8	3TF32	16	#	5.5 - 8
5.5/7.5	11.2	3RV11 21-1KA10	12.5	3TF34	32	#	9 - 12.5
7.5/10	16	3RV11 21-4AA10	16	3TF34	32	#	11 - 16
9.3/12.5	19	3RV11 21-4BA10	20	3TF34	32	#	14 - 20
11/15	20.8	3RV11 21-4CA10	22	3TF34	32	#	17 - 22
15/20	28	3RV11 31-4EA10	32	3TF35	38	#	22 - 32
18.5/25	34	3RV11 31-4FA10	40	3TF46	45	#	28 - 40
22/30	40	3RV11 31-4GA10	45	3TF48	75	#	36 - 45
30/40	53	3RV11 42-4JA10	63	3TF48	75	#	45 - 63
37/50	65	3RV11 42-4KA10	75	3TF50	110	#	57 - 75
45/60	78	3RV11 42-4LA10	90	3TF50	110	#	70 - 90
55/75	96	3RV11 42-4MA10	100	3TF52	170	#	80 - 100
75/100	131	3VL27 16-1DK36-0AA0	160	3TF52	170	3UA62 30-5A	85-135
90/125	156	3VL37 25-1DK36-0AA0	250	3TF53	205	3UA62 30-5B	115-180
110/150	189	3VL37 25-1DK36-0AA0	250	3TF53	205	3UA62 30-5C	160 - 250
132/180	227	3VL37 25-1DK36-0AA0	250	3TF54	250	3UA62 30-5C	160 - 250
160/215	271	3VL47 31-1DK36-0AA0	315	3TF55	300	3UA62 30-5D	200 - 320
200/270	339	3VL57 50-1DK36-0AA0	500	3TF57	475	3UA62 30-5E	250 - 400
250/335	398	3VL57 50-1DK36-0AA0	500	3TF57	475	3UA68 30-5F	320 - 500

#3RV11 comes with integral relay function, hence external bi-relay is eliminated.

MPCB with 'standard release' can also be used.

Star-delta feeder, for low LCC

SL motor			Circuit breaker		Contactor line/delta		Contactor star		Bi-relay		Timer
kW/HP 415V, 3ph, 50Hz	IL A	Iph A	Type	A	Type	A	Type	A	Type (50°C)	Range (A)	Type
2.2/3	4.8	2.8	3RV13 21-1FC10	5	3TF32	16	3TF30	9	3UA52 00-1D	2 - 3.2	3RP15
3.7/5	7.8	4.5	3RV13 21-1HC10	8	3TF32	16	3TF30	9	3UA52 00-1F	3.2 - 5	3RP15
5.5/7.5	11.2	6.5	3RV13 21-1KC10	12.5	3TF34	32	3TF30	9	3UA52 00-1H	5 - 8	3RP15
7.5/10	16	9.2	3RV13 21-4AC10	16	3TF34	32	3TF30	9	3UA52 00-1J	6.3 - 10	3RP15
9.3/12.5	19	11	3RV13 21-4CC10	22	3TF34	32	3TF30	9	3UA52 00-1K	8 - 12.5	3RP15
11/15	20.8	12	3RV13 21-4CC10	22	3TF34	32	3TF30	9	3UA52 00-1K	8 - 12.5	3RP15
15/20	28	16.2	3RV13 31-4EC10	32	3TF35	38	3TF32	16	3UA52 00-2B	12.5 - 20	3RP15
18.5/25	34	19.7	3RV13 31-4FC10	40	3TF46	45	3TF34	32	3UA52 00-2C	16 - 25	3RP15
22/30	40	23.2	3RV13 31-4GC10	45	3TF48	75	3TF34	32	3UA52 00-2C	16 - 25	3RP15
30/40	53	30.6	3RV13 41-4JC10	63	3TF48	75	3TF34	32	3UA55 00-2D	20 - 32	3RP15
37/50	65	37.5	3RV13 41-4KC10	75	3TF50	110	3TF34	32	3UA55 00-2R	32 - 40	3RP15
45/60	78	45	3RV13 41-4LC10	90	3TF50	110	3TF34	32	3UA55 00-8M	36 - 45	3RP15
55/75	96	55.4	3RV13 41-4MC10	100	3TF52	170	3TF34	32	3UA58 00-2TZ1	40 - 57	3RP15
75/100	131	75.6	3VL27 16-1DK36-0AA0	160	3TF52	170	3TF47	63	3UA58 00-8YZ1	70 - 95	3RP15
90/125	156	90.1	3VL37 25-1DK36-0AA0	250	3TF53	205	3TF47	63	3UA58 30-5B	70 - 95	3RP15
110/150	189	109	3VL37 25-1DK36-0AA0	250	3TF53	205	3TF50	110	3UA58 30-5D	95 - 120	3RP15
132/180	227	131.1	3VL37 25-1DK36-0AA0	250	3TF54	250	3TF50	110	3UA62 30-5B	115 - 180	3RP15
160/215	271	156.5	3VL47 31-1DK36-0AA0	315	3TF55	300	3TF50	110	3UA62 30-5B	115 - 180	3RP15
200/270	339	195.7	3VL57 50-1DK36-0AA0	500	3TF57	475	3TF52	170	3UA62 30-5C	160 - 250	3RP15
250/335	398	229.8	3VL57 50-1DK36-0AA0	500	3TF57	475	3TF54	250	3UA62 30-5D	160 - 250	3RP15

Recommended Selection of Switchgear for Autotransformer Starter - Fuseless

SL Motor, 415V, 3Ph, 50Hz		MPCB / MCCB*		Line contactor K3		Transformer contactor K2 for Transformer tapping % star contactor K1 = same as transformer contactor K2								Overload Relay	
kW / HP	IL Amp	MLFB	Range Amp	Type	A	80%		70%		65%		50%		Type	A
						Type	A	Type	A	Type	A	Type	A		
2.2 / 3	4.8	3RV10211FC10	5	3TF30	9	3TF30	9	3TF30	9	3TF30	9	3TF30	9	-	-
3.7 / 5	7.8	3RV10211HC10	8	3TF30	9	3TF30	9	3TF30	9	3TF30	9	3TF30	9	-	-
5.5 / 7.5	11.2	3RV10211KC10	12.5	3TF31	12	3TF30	9	3TF30	9	3TF30	9	3TF30	9	-	-
7.5 / 10	16	3RV10214AC10	16	3TF32	16	3TF31	12	3TF30	9	3TF30	9	3TF30	9	-	-
9.3 / 12.5	19	3RV10214BC10	20	3TF33	16	3TF32	16	3TF31	12	3TF30	9	3TF30	9	-	-
11 / 15	20.8	3RV10214CC10	22	3TF33	22	3TF32	16	3TF31	12	3TF31	12	3TF30	9	-	-
15 / 20	28	3RV10314EC10	32	3TF34	32	3TF33	22	3TF32	16	3TF32	16	3TF30	9	-	-
18.5 / 25	34	3RV10314FC10	40	3TF35	38	3TF34	32	3TF33	22	3TF32	16	3TF31	12	-	-
22 / 30	40	3RV10314GC10	45	3TF46	45	3TF34	32	3TF33	22	3TF33	22	3TF31	12	-	-
30 / 40	53	3RV10414JC10	63	3TF47	63	3TF35	38	3TF34	32	3TF34	32	3TF32	16	-	-
37 / 50	65	3RV10414KC10	75	3TF477	70	3TF46	45	3TF35	38	3TF34	32	3TF33	22	-	-
45 / 60	78	3RV10414LC10	90	3TF49	85	3TF47	63	3TF46	45	3TF35	38	3TF34	32	-	-
55 / 75	96	3RV10414MC10	100	3TF50	110	3TF477	70	3TF47	63	3TF46	45	3TF34	32	-	-
75 / 100	131	3VL2716-1DK36-0AA0	160	3TF51	140	3TF49	85	3TF48	75	3TF47	63	3TF46	45	3UA6230-5A	85 - 135
90 / 125	156	3VL3725-1DK36-0AA0	250	3TF52	170	3TF50	110	3TF49	85	3TF477	70	3TF47	63	3UA6230-5B	115 - 180
110 / 150	189	3VL3725-1DK36-0AA0	250	3TF53	205	3TF51	140	3TF50	110	3TF49	85	3TF47	63	3UA6230-5C	160 - 250
132 / 180	227	3VL3725-1DK36-0AA0	250	3TF54	250	3TF52	170	3TF51	140	3TF50	110	3TF477	70	3UA6230-5C	160 - 250
160 / 215	271	3VL4740-1DK36-0AA0	400	3TF55	300	3TF53	205	3TF51	140	3TF51	140	3TF50	110	3UA6230-5D	200 - 320
200 / 270	339	3VL4740-1DK36-0AA0	400	3TF56	400	3TF54	250	3TF52	170	3TF52	170	3TF50	110	3UA6230-5E	250 - 400
250 / 335	398	3VL5763-2DK36-0AA0	630	3TF57	475	3TF55	300	3TF53	205	3TF53	205	3TF51	140	3UA6830-3F	320 - 500

* 3RV10 MBCB comes with built in overload protection hence no need to use an external overload relay; 3RV13 Mag only MPCB can also be used, however an external overload relay is required

1. Please use Electronic Star delta time type 3RP15 for the changeover from star to main.

2. Selection valid for Normal starting of the motors with starting time upto 10 seconds

3. Minimum auxiliary contacts for K1= 1NO+1NC, for K2=1NO, for K3=1NC and for contactor relay K5=2NO

4. Selection for higher ratings upon request.

Recommended Selection of Switchgear for Autotransformer Starter - Fuse Protected

SL Motor, 415V, 3Ph, 50Hz		SDF		FUSE		Line contactor K3		Transformer contactor K2 for Transformer tapping % star contactor K1 = same as transformer contactor K2								Overload Relay	
kW / HP	IL Amp	MLFB	Rating Amp	MLFB	Rating Amp	Type	A	80%		70%		65%		50%		Type	A
								Type	A	Type	A	Type	A	Type	A		
2.2 / 3	4.8	3KL812	32	3NA78010RC	6	3TF30	9	3TF30	9	3TF30	9	3TF30	9	3TF30	9	3UA5000-1F	3.2 - 5
3.7 / 5	7.8	3KL812	32	3NA78030RC	10	3TF30	9	3TF30	9	3TF30	9	3TF30	9	3TF30	9	3UA5000-1H	5 - 8
5.5 / 7.5	11.2	3KL812	32	3NA78050RC	16	3TF31	12	3TF30	9	3TF30	9	3TF30	9	3TF30	9	3UA5000-1K	8 - 12.5
7.5 / 10	16	3KL812	32	3NA78070RC	20	3TF32	16	3TF31	12	3TF30	9	3TF30	9	3TF30	9	3UA5200-2A	10 - 16
9.3 / 12.5	19	3KL812	32	3NA78100RC	25	3TF33	16	3TF32	16	3TF31	12	3TF30	9	3TF30	9	3UA5500-2B	12.5 - 20
11 / 15	20.8	3KL812	32	3NA78100RC	25	3TF33	22	3TF32	16	3TF31	12	3TF31	12	3TF30	9	3UA5500-2C	16 - 25
15 / 20	28	3KL815	63	3NA78120RC	32	3TF34	32	3TF33	22	3TF32	16	3TF32	16	3TF30	9	3UA5500-2D	20 - 32
18.5 / 25	34	3KL815	63	3NA78200RC	50	3TF35	38	3TF34	32	3TF33	22	3TF32	16	3TF31	12	3UA5500-2Q	25 - 36
22 / 30	40	3KL815	63	3NA78200RC	50	3TF46	45	3TF34	32	3TF33	22	3TF33	22	3TF31	12	3UA5800-2FZ1	32 - 50
30 / 40	53	3KL815	63	3NA78220RC	63	3TF47	63	3TF35	38	3TF34	32	3TF34	32	3TF32	16	3UA5800-2TZ1	40 - 57
37 / 50	65	3KL821	100	3NA78240RC	80	3TF477	70	3TF46	45	3TF35	38	3TF34	32	3TF33	22	3UA5800-2VZ1	57 - 70
45 / 60	78	3KL821	100	3NA78300RC	100	3TF49	85	3TF47	63	3TF46	45	3TF35	38	3TF34	32	3UA5800-8YZ1	70 - 95
55 / 75	96	3KL821	100	3NA78300RC	100	3TF50	110	3TF477	70	3TF47	63	3TF46	45	3TF34	32	3UA5830-5C	85 - 105
75 / 100	131	3KL831	200	3NA78360RC	160	3TF51	140	3TF49	85	3TF48	75	3TF47	63	3TF46	45	3UA6230-5A	85 - 135
90 / 125	156	3KL831	200	3NA78360RC	160	3TF52	170	3TF50	110	3TF49	85	3TF477	70	3TF47	63	3UA6230-5B	115 - 180
110 / 150	189	3KL831	200	3NA71400RC	200	3TF53	205	3TF51	140	3TF50	110	3TF49	85	3TF47	63	3UA6230-5C	160 - 250
132 / 180	227	3KL832	250	3NA71440RC	250	3TF54	250	3TF52	170	3TF51	140	3TF50	110	3TF477	70	3UA6230-5C	160 - 250
160 / 215	271	3KL833	315	3NA72520RC	315	3TF55	300	3TF53	205	3TF51	140	3TF51	140	3TF50	110	3UA6230-5D	200 - 320
200 / 270	339	3KL834	400	3NA72600RC	400	3TF56	400	3TF54	250	3TF52	170	3TF52	170	3TF50	110	3UA6230-5E	250 - 400
250 / 335	398	3KL834	400	3NA72600RC	400	3TF57	475	3TF55	300	3TF53	205	3TF53	205	3TF51	140	3UA6830-3F	320 - 500

1. Please use Electronic Star delta time type 3RP15 for the changeover from star to main.

2. Selection valid for Normal starting of the motors with starting time upto 10 seconds

3. Minimum auxiliary contacts for K1= 1NO+1NC, for K2=1NO, for K3=1NC and for contactor relay K5=2NO

4. Selection for higher ratings upon request.

Your partners

Sales offices:

Ahmedabad

3rd Floor, Purna Arbour
Garkheda Parisar Cross Roads, Off. C. G. Road
Ahmedabad - 380009
☎ : +91 79 40207600
Fax: +91 79 40207699

Bengaluru

1st Floor, Jyothimahal, #49, St. Marks Road
Bengaluru - 560001
☎ : +91 80 22042000
Fax: +91 80 22224131

Chandigarh

SCO 189 - 191, 3rd Floor, Sector 17C
Chandigarh - 160017
☎ : +91 172 4690300
Fax: +91 172 4690399

Territory managers:

Aurangabad

A9, Yogeshwari Vrundavan, Nr. Malhar Chowk
Garkheda Parisar, Prema Nagar
Aurangabad - 431210, Maharashtra
Mobile: +91 9766316446
E-mail: santosh.rajhans@siemens.com

Bareilly

Bareilly - 243001, Uttar Pradesh
Mobile: +91 9415012500
E-mail: saket.dwivedi@siemens.com
Mobile: +91 9897070133
E-mail: ankur.singh@siemens.com

Baroda

1st Floor, Vaniiya Bhavan, Race Course Road
Baroda - 390007, Gujarat
☎ : +91 265 2325810/12, 6692110
Mobile: +91 98255 06963
Email: ankur.chokshi@siemens.com
Mobile: +91 98255 06962
Email: bhushan.sawant@siemens.com

Belgaum

H.No.713, Narvekar Lane, Shahpur
Belgaum - 590003, Karnataka
☎ & Fax: +91 831 2495156
Mobile: +91 9740277991
E-mail: anand.gawade@siemens.com

Bhilai

C/o Mr. S.H Siddiqui
Sector-1, Street-9, Quarter No 1A
Bhilai - 490001, Chhattisgarh
Mobile: +91 9823011883

Bhopal

Flat No - 104, Sagar Home Phase-2
Sarvadharm Society, Nayapura Road
Bhopal - 462042, MP
Mobile: +91 9977228084
Email: Prajwal.khapekar@siemens.com

Bhubaneswar

Flat No.109, Hara Priya Apartment
Vivekananda Marg, Bhubaneswar - 751002, Orissa
☎ : +91 674 2430734
Mobile: +91 9937009749
E-mail: anirban.aditya@siemens.com
Mobile: +91 9937097504
E-mail: sumit.sengupta@siemens.com

Calicut

Kozhikode, Calicut - 673001, Kerala
Mobile: +91 9895052944
E-mail: sreekanth.p@siemens.com

Deharadun

B 76, Kumar Gali, Ajabpurkalan
Deharadun - 248001, Uttarakhand
Mobile: +91 9760033117
E-mail: manish.bajpai@siemens.com

Durgapur

Durgapur - 713216, West Bengal
Mobile: +91 9830610022
E-mail: chattopadhyay.suman@siemens.com

Faridabad

House No 237, Sector-8
Faridabad - 121006, Haryana
Mobile: +91 987396350
E-mail: ramit.mehra@siemens.com

Chennai

4, Mahatma Gandhi Road, Chennai - 600034
☎ : +91 44 28334000
Fax: +91 44 28334088

Coimbatore

7th Floor, East Wing, Global Towers
1057, Avinashi Road, Coimbatore - 641018
☎ : +91 422 4336300
Fax: +91 422 4336310

Hyderabad

5-9-19, Lakshmi Narsinh Estate, 4th Floor
Secretariat Road, Opp. Secretariat, Saifabad
Hyderabad - 500004
☎ : +91 40 23482500
Fax: +91 40 23243145

Gurgaon

House No-38, Second Floor, Sector-30
Gurgaon - 122001, Haryana
Mobile: +91 9971091588
E-mail: manjeet.mor@siemens.com

Guwahati

G1, Hill View Apartment, Navagraha Path
Chenikuthi Hill Side, Guwahati - 781003, Assam
☎ : +91 361 2663988
Mobile: +91 9864037562
E-mail: sourav.bhattacharya@siemens.com
Mobile: +91 9864110684
E-mail: biplab.datta@siemens.com

Hardwar

6, Nand Puri, Near Arya Nagar Chowk, Jwalapur
Hardwar - 249407, Uttarakhand
Mobile: +91 9897070133
Fax: +91 1334 265491
E-mail: ankur.singh@siemens.com

Indore

Flat No. 102, Panchvati Apartment
40 Chandralok Colony, Khajrana Road
Indore - 452001, Madhya Pradesh
Mobile: +91 9926939993
E-mail: prashant.joshi@siemens.com

Jaipur

6, Park Street, Opp Pink City Petrol Pump, M.I.Road
Jaipur - 302006, Rajasthan
☎ : +91 141 2370274 / 2377956
Fax: +91 141 2370482
Mobile: +91 9829244313
E-mail: peeush.gupta@siemens.com

Jalandar

H.No 448R, First Floor, Pushpa Niwas
Near Geeta Mandir, Model Town
Jalandar - 144001, Punjab
Mobile: +91 9779194445
E-mail: sunil.singla@siemens.com

Jamshedpur

823, Udaigiri, Vijaya Heritage, Uliyan, Kadma
Jamshedpur - 831005, Jharkhand
☎ : +91 657 6451637
Mobile: +91 9934311352
E-mail: shaibal.parial@siemens.com

Jodhpur

371, Gauri House, Kamala Nehru Nagar
Near SBI Bank, Jodhpur - 342008, Rajasthan
Mobile: +91 9828327200
E-mail: naveen.sahariya@siemens.com

Kanpur

106, Agarwal Apartment
Near Hari Har Dham Mandir, Shyam Nagar
Kanpur - 208013, Uttar Pradesh
☎ & Fax: +91 512 2423348
Mobile: +91 9839102434
E-mail: atul.shukla@siemens.com

Kochi

KG Oxford Business Centre, 39/4609, Third Floor
Sreekandath Road, Ravipuram
Cochin - 682016, Kerala
☎ : +91 484 4028611, 22
Fax: +91 484 2380201
Mobile: Sajeen +91 9744511109
E-mail: sajeen.s@siemens.com
Mobile: Sudheer +91 9387384848
E-mail: sudheer.ts@siemens.com

Kolkata

43 Shanti Palli, R B Connector
Eastern Metropolitan Bypass, Kolkata - 700042
☎ : +91 33 24449000, 24428641-47
Fax: +91 33 24449010 / 13

Lucknow

28/45, Ashok Marg, Opposite Indira Bhawan
Lucknow - 226001
☎ : +91 522 4031022, 4031000
Fax: +91 522 4031019

Mumbai

R&D Technology Centre
Thane Belapur Road, Airoli Node
Navi Mumbai - 400 708
☎ : +91 22 27645005-06
Fax: +91 22 27645867

Kolhapur

Flat No. 101, Shrushti Mahabharat Apartment
Mahavir Garden To Mahavir College Road
Nagala Park, Kolhapur - 416003, Maharashtra
☎ : +91 231 2663330
Mobile: +91 9881465421
E-mail: sachin.chavan@siemens.com

Ludhiana

H.No 3746, First Floor, Sector 32-A
Chandigarh Road, Ludhiana - 141010, Punjab
Mobile: +91 9872317702
E-mail: rajeev.kapoor@siemens.com

Ludhiana

H.No 92, Lajpat Nagar, Near Bus Stand
Ludhiana - 141010, Punjab
☎ : +91 161 2770574
Mobile: +91 9815502480
E-mail: rohit.jagga@siemens.com

Madurai

8/12, Ground Floor, Sakhti Vellammal Street
SS Colony, Madurai - 625010, Tamilnadu
Mobile: +91 9894617780
E-mail: mahendiran.murugan@siemens.com

Nashik

"Aditya Avenue", Flat No. 27, 4th Floor
B Wing, Near Chandak Circle, Tidke Colony
Nashik - 422001, Maharashtra
Mobile: +91 9822193204
E-mail: kiran.kanhurkar@siemens.com

Pondicherry

32, Second Floor, St. Theresa Street
Pondicherry - 605001
☎ : +91 413 4500101
Mobile: +91 9840143536
E-mail: lakshamanan.s@siemens.com

Raipur

Flat No.103, First Floor, Block B, Shilp Enclave
Near LAS Colony, Shankar Nagar
Raipur - 492007, Chhattisgarh
Mobile: +91 9425057945
E-mail: brajesh.rathor@siemens.com

Rajkot

"Vruraj", 4 Chandanpark Society
Opp. Gyanganga Vidhyapith, Nr. Raiya Circle
Rajkot - 360005, Gujarat
Mobile: +91 9825021026
E-mail: hiren.raythatha@siemens.com

Ranchi

H-1/187, Harmu Housing Colony, Harmu
Ranchi - 834002, Jharkhand
Mobile: +91 9234610953
E-mail: sourav.dasgupta@siemens.com

Renukoot

Above ICICI Prudentail Office, Patel Nagar
Murdhawa, Dist-Sonebhadra
Renukoot - 231217, Uttar Pradesh
Mobile: +91 9838007897
E-mail: bhav.srivastava@siemens.com

Rourkela

T-15, Civil Town, Rourkela - 769004, Orissa
☎ : +91 661 2400880
Mobile: +91 94370471724
E-mail: sanjoy.ganguly@siemens.com

Nagpur

5th Floor, Landmark Building, Ramdas Peth
Nagpur - 440010
☎ : +91 712 6633000
Fax: +91 712 6633111

New Delhi

4A, Ring Road, I.P. Estate, New Delhi - 110002
☎ : +91 11 42995000-09
Fax: +91 11 42995030

Pune

Tower B / 701 - 705, ICC Trade Tower
403A, Senapati Bapat Road, Pune - 411016
☎ : +91 20 25706000
Fax: +91 20 25706060

Rudrapur

Rudrapur - 263153, Uttarakhand
Mobile: +91 9838913707
E-mail: singh.ajay@siemens.com

Salem

3/25 Santosh Nagar, PACB Backside
Chinnathirupathi, Salem - 636008, Tamilnadu
Mobile: +91 9894617772
E-mail: rubengerald@siemens.com

Sambalpur

Pradhan Para, Near Jamkani Mandir
Beside LIC Div Off, Ainthapalli
Sambalpur - 768004, Orissa
☎ : +91 663 2541258
Mobile: +91 9438529778
E-mail: samirchaintak@siemens.com

Surat

Flat No. 202, D-1, Suryam Residence
Cause Way Road, Opp. Hari Darshan
Shinganpor - Dabholi Road, Katargam
Surat - 395004, Gujarat
Mobile: +91 9925001779
E-mail: chandrakant.keshrani@siemens.com

Tiruchirappali

Door No. 106, Ground Floor, 5th Cross Street
Vidhyasalai Road, Ganapathy Nagar
Thiruvanaikoil, Trichy
Tiruchirappali - 620017, Tamilnadu
☎ & Fax: +91 431 4345621
Mobile: +91 9840843121
E-mail: k.saravanakumar@siemens.com

Thiruvananthapuram

Sonu, TC9/2082, 5, Thamarakulam Lane
Sathamangalam, Trivendrum - 695010, Kerala
Mobile: +91 9895979604
E-mail: jonsa_82@yahoo.com

Udaipur

303, Oasis Park, PP Singhal Marg, Ambavgarh
Udaipur - 313001, Rajasthan
☎ & Fax: +91 294 2430345
Mobile: +91 9829039120
E-mail: ajit.parashar@siemens.com

Vapi

Flat No. 302, Samrajya IV, Royal Residency
Gokul Vihar Township, Charwada Road
Vapi - 396195, Gujarat
☎ : +91 260 6451156
Mobile: +91 9825147957
E-mail: sachin.pardkar@siemens.com

Vijayawada

G-2, Shreya Tower, Moghalrajapuram
Near Jammichettu Centre
Vijayawada - 520010, Andhra Pradesh
☎ : +91 866 6629933
Mobile: +91 9866463639
E-mail: santosh.p@siemens.com

Visakhapatnam

Flat No. 401, Door No. 9-19-36
Vinayagar West Avenue, CBM compound
Visakhapatnam - 530003, Andhra Pradesh
☎ : +91 891 2712535
Mobile: +91 9849212555
E-mail: ksv.prasad@siemens.com

Siemens Ltd.
Industry Sector
Industry Automation - Control Components
R&D Technology Centre
Thane Belapur Road, Airoli Node, Navi Mumbai - 400 708
Fax: +91 22 27645627
E-mail: lvsg-rmktg.india@siemens.com

www.siemens.com/industry

Order No.: 102835843
SGR-01-117-007

Customer Care Toll free no. 1800 220 987
Email: adscs.india@siemens.com

Product upgradation is a continuous process. Hence, data in this catalog is subject to change without prior notice. For the latest information, please get in touch with our Sales Offices.